

MIYAWAKI

BALL FLOAT STEAM TRAP

G3N / G5

USER'S MANUAL

- 1. SYMBOL USED**
- 2. SAFETY INSTRUCTIONS**
- 3. SPECIFICATIONS**
- 4. NAMES OF COMPONENTS AND PARTS**
- 5. INSTALLATION**
- 6. MAINTENANCE**
- 7. TROUBLESHOOTING**
- 8. LIMITED WARRANTY**

Be sure to read this manual to learn the safe and proper operation of this product.
Store this manual carefully after use.



To the owner

Ball float steam trap, model G3N / G5 is designed for large capacities with a built-in Diaphragm type air vent and a double ported balance valve.

In order to get maximum benefit from this product, be sure to read this manual before installing it.

Maintenance

If this product functions or looks abnormal, take the necessary steps to correct it.

If it seemingly cannot be corrected, ask your MIYAWAKI dealer what to do and give him the following information.

- (1) Model
- (2) Serial (S)/ No.
- (3) Detailed description of the abnormal condition

Supply Period for Maintenance Parts

We will continue to supply maintenance parts for this product for 5 years after we discontinue production of the primary product.

The supply of maintenance parts will, in principle, terminate at the end of the supply period stated above. However, even after the supply period has run out, it is possible to consult with us about the delivery time and prices for parts that are still in stock.

1 SYMBOL USED

● SYMBOL INDICATION



(1) Safety-alert Symbol

This is the safety-alert symbol. When this symbol is on the machine or in this manual, be alert to the possibility of personal injury and carefully read the messages that follow.

(2) Signal words

The signal words "WARNING", "CAUTION" are used with the safety-alert symbol.



WARNING

"WARNING" denotes an extreme hazard which will likely result in death or serious personal injury if proper precautions are not taken.



CAUTION

"CAUTION" denotes general precautions that may result in injury or damage to objects if proper precautions are not taken.

2 SAFETY INSTRUCTIONS

Observe the following instructions to insure safe operation. If you don't, you may be seriously injured and the product may be damaged.

- * Be sure not to use this product at a pressure higher than the specified maximum operating pressure (PMO) or at a temperature higher than the specified maximum operating temperature (TMO).
- * Pay very careful attention when working in hazardous environments such as:
Places with any risk of explosion and/or the possibility of dangerous gas leaking.
- * Always check whether the pipeline contains flammable, high pressure or high temperature materials before starting to work.
- * Make sure that isolation valves are installed on both the upstream and downstream lines.
- * Before installing the product, open the isolation valves, and the bypass valve, if one exists, to blow off any debris or dust inside the pipeline.
- * When installing the product, be sure to leave clearance for the maintenance.
- * When replacing parts, make sure the replacement parts are supplied by MIYAWAKI.

3 SPECIFICATIONS

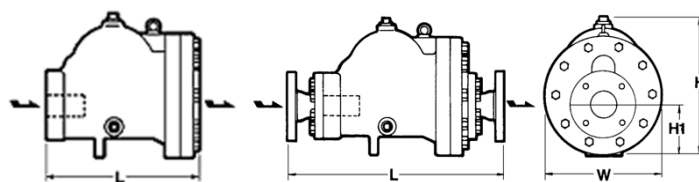

MODEL NO.	CONNECTION		BODY MATERIAL	OPERATING PRESSURE MPa (psig)	MAX. TEMP. °C (° F)	DIMENSIONS mm (inch)				WEIGHT kg (lb)
	TYPE	SIZE mm (inch)				L	H	H1	W	
G3N-10	Flanged	40 (1-1/2)	Ductile Cast Iron (FCD450)	0.01~1.0 (1.45~145)	235 (455)	265 (10.4)	235 (9.3)	95 (3.7)	198 (7.8)	22 (48.4)
G3N-16				0.01~1.6 (1.45~230)						
G5-10	Flanged	50 (2)	Ductile Cast Iron (FCD450)	0.01~1.0 (1.45~145)	235 (455)	339 (13.3)	315 (12.4)	110 (4.3)	270 (10.6)	45 (99.0)
G5-16				0.01~1.6 (1.45~230)						
G3N-10R	Flanged	40 ~ 80 (1-1/2 ~ 3)	Ductile Cast Iron (FCD450)	0.01~1.0 (1.45~145)	235 (455)	*	235 (9.3)	95 (3.7)	198 (7.8)	*
G3N-16R				0.01~1.6 (1.45~230)						
G5-10R	Flanged	50 ~ 100 (2~4)	Ductile Cast Iron (FCD450)	0.01~1.0 (1.45~145)	235 (455)	*	315 (12.4)	110 (4.3)	270 (10.6)	*
G5-16R				0.01~1.6 (1.45~230)						

* Refer to Table A

Table A: Dimensions and Weight of Flange Types

MODEL NO.	SIZE mm (inch)	FLANGE RATING	L mm (inch)	WEIGHT kg (lb)
G3N-10R G3N-16R	25 (1)	JIS10K, 16K, 20K	427 (17.0)	27.0 (60)
		ANSI-JPI 150lb, 300lb	437 (17.5)	27.5 (61)
	32 (1-1/4)	JIS10K, 16K, 20K	427 (17.0)	27.5 (61)
		ANSI-JPI 150lb, 300lb	437 (17.5)	28.0 (62)
	40 (1-1/2)	JIS10K, 16K, 20K	437 (17.5)	28.0 (62)
		ANSI-JPI 150lb, 300lb	437 (17.5)	30.0 (66)
	50 (2)	JIS10K, 16K, 20K	457 (18.3)	29.0 (64)
		ANSI-JPI 150lb, 300lb	467 (18.7)	31.0 (68)
	65 (2-1/2)	JIS10K, 16K, 20K	487 (19.5)	36.0 (79)
		ANSI-JPI 150lb, 300lb	497 (19.9)	36.0 (79)
	80 (3)	JIS10K, 16K, 20K	487 (19.5)	41.0 (90)
		ANSI-JPI 150lb, 300lb	497 (19.9)	41.0 (90)
G5-10R G5-16R	50 (2)	JIS10K, 16K, 20K	540 (21.6)	52.0 (115)
		ANSI-JPI 150lb, 300lb	540 (21.6)	54.0 (119)
	65 (2-1/2)	JIS10K, 16K, 20K	560 (22.4)	54.0 (119)
		ANSI-JPI 150lb, 300lb	570 (22.8)	57.0 (126)
	80 (3)	JIS10K, 16K, 20K	560 (22.4)	56.0 (123)
		ANSI-JPI 150lb, 300lb	570 (22.8)	60.0 (132)
	100 (4)	JIS10K, 16K, 20K	580 (23.2)	59.0 (130)
		ANSI-JPI 150lb, 300lb	600 (24.0)	69.0 (152)

4 NAME OF COMPONENTS AND PARTS

MODEL G3N

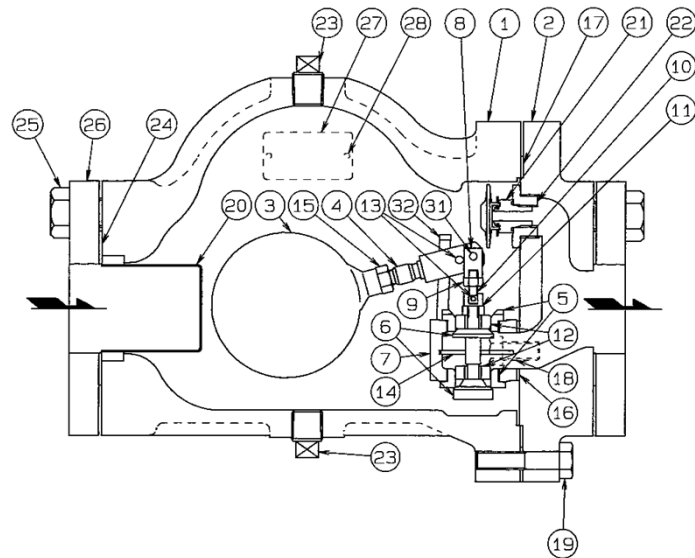

MODEL G3N-R

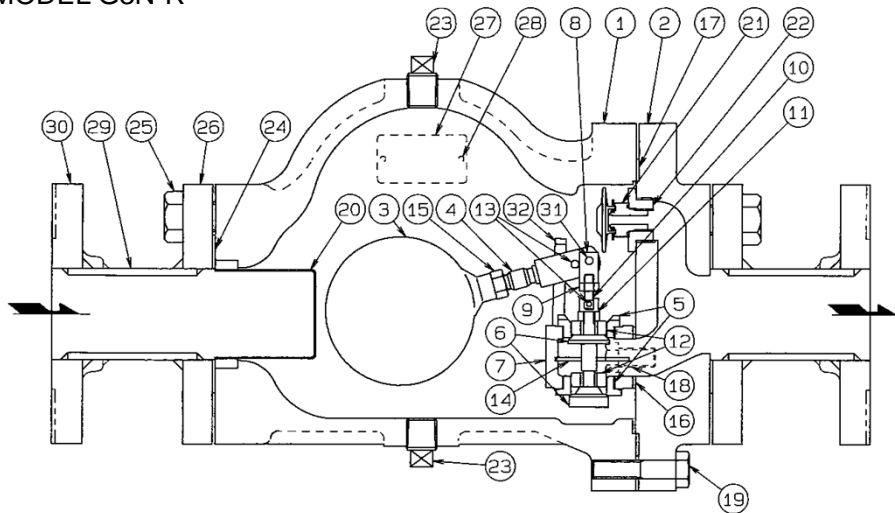

- | | | |
|---------------|------------------|-----------------------------|
| 1. Body | 12. Guide Wing | 23. Plug |
| 2. Cover | 13. Pin | 24. Gasket |
| 3. Float | 14. Baffle Plate | 25. Bolt |
| 4. Lever | 15. Nut | 26. Flange |
| 5. Valve Seat | 16. Gasket | 27. Name Plate |
| 6. Valve | 17. Gasket | 28. Rivet |
| 7. Holder | 18. Bolt | 29. Pipe (for only G3N-R) |
| 8. Lever Nut | 19. Bolt | 30. Flange (for only G3N-R) |
| 9. Nut | 20. Screen | 31. Pin |
| 10. Connector | 21. Air Vent | 32. Stopper |
| 11. Nut | 22. Bush | |

MODEL G5

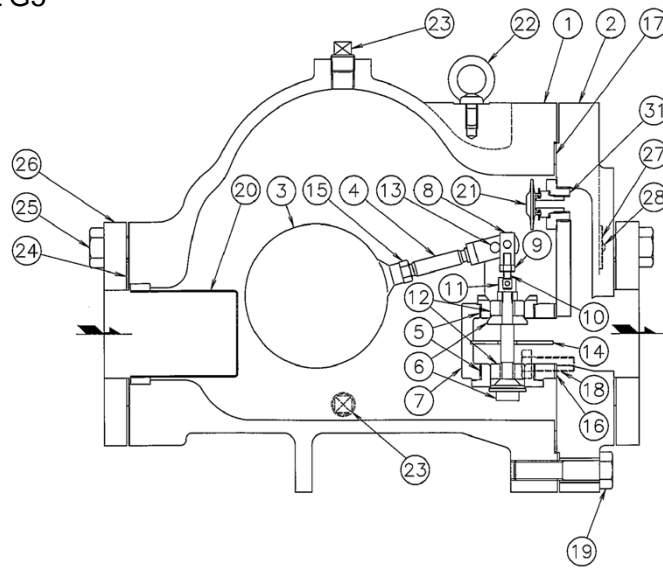

MODEL G5-R

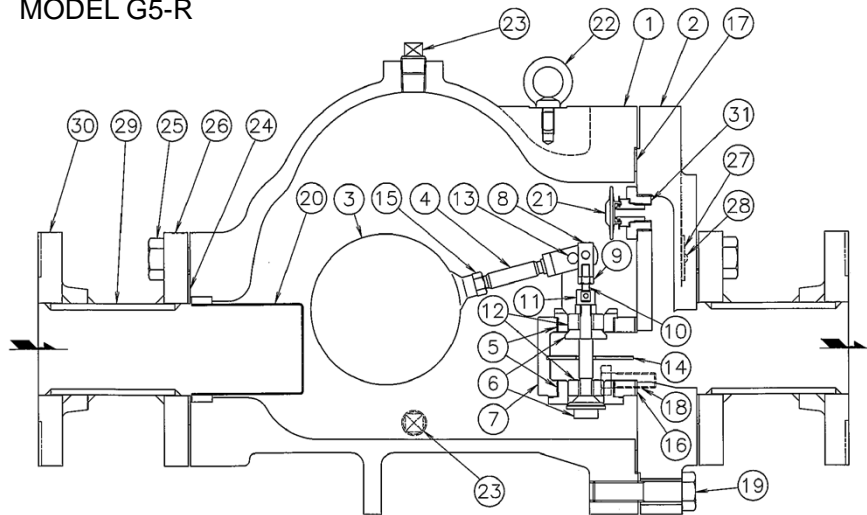

- | | | |
|---------------|------------------|----------------------------------|
| 1. Body | 12. Guide Wing | 23. Plug |
| 2. Cover | 13. Pin | 24. Gasket |
| 3. Float | 14. Baffle Plate | 25. Bolt |
| 4. Lever | 15. Nut | 26. Flange |
| 5. Valve Seat | 16. Gasket | 27. Name Plate |
| 6. Valve | 17. Gasket | 28. Rivet |
| 7. Holder | 18. Bolt | 29. Pipe/Reducer (for only G5-R) |
| 8. Lever Nut | 19. Bolt | 30. Flange (for only G5-R) |
| 9. Nut | 20. Screen | 31. Bush |
| 10. Connector | 21. Air Vent | |
| 11. Nut | 22. Eyebolt | |

5 INSTALLATION



Before installing the product, open the isolation valves, and the bypass valve, if one exists, to blow off any debris or dust inside the pipeline.

CAUTION

- (1) G3N, G5 are for horizontal installation.
- (2) Check the flow direction marked on the side of the body, and match it with the arrow on the trap body.
- (3) Be sure to create a slight downhill gradient so that the condensate will flow in and out smoothly.
- (4) The product should be installed for easy maintenance check.
- (5) Open the isolation valve on the primary line slowly and make sure the product works properly.

* The example of correct installation is shown below.

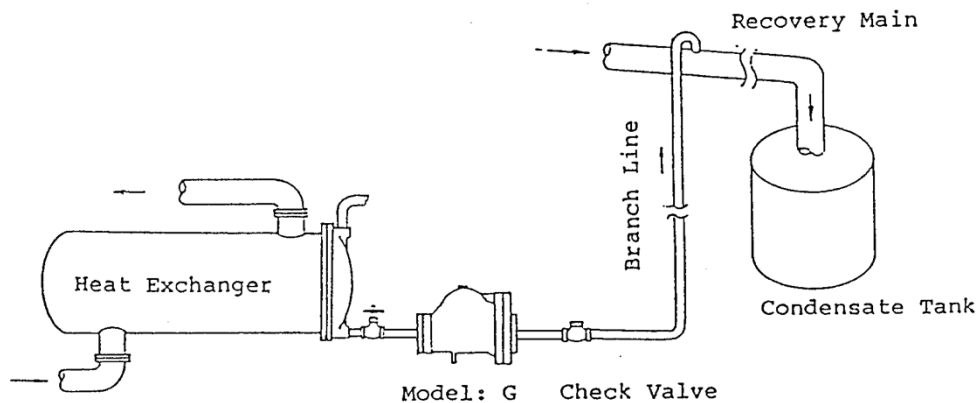

6 MAINTENANCE



WARNING

When taking apart the trap from the line, close the both primary and secondary stop valve, and cool down the trap itself first to avoid the danger of steam and condensate blowout.

The performance of steam traps deteriorates over time due to wear, corrosion, or dirt accumulating around the valve seat. To keep steam systems and equipment working well, periodic maintenance of the steam traps is essential.

Tools for testing steam traps

In order to test steam traps, ultrasonic testers, sound detectors, and thermometers have been used for years. These tools are relatively easy to use and are useful for making rough estimates of the level of deterioration in a defective trap. However, to determine deterioration levels and steam losses quantitatively, special tools are required for testing steam traps.

Dr. Trap and Dr. Trap Jr. are testing equipment that were developed specifically for diagnosing steam traps and analyzing survey results automatically. Use these tools to avoid tiresome jobs on sites and save working time.

Working conditions of a steam trap

Steam trap failures can be classified as either 'Leaking' or 'Plugged'. The level of steam leaks is generally determined by the intensity of the ultrasonic vibration generated in the valve seat inside of a steam trap. The 'plugged' is diagnosed by measuring the surface temperature.

As the degree of plugging increases due to a buildup of dirt in the trap, it will finally become completely plugged.

If this occurs, the surface temperature will drop to around 40 degrees centigrade, or lower.

Repairs

When a trap fails, it is necessary to clean the internal parts and replace damaged parts. Take the failed trap apart following the steps below.

A. Take apart the body of the trap

(1) Remove the trap from the piping. Take off the Bolt (25) and remove the connection flange.

(2) Remove the screen (20).

(3) Remove the Bolt (19) and the Cover (2).

(4) Firm the Cover (2) with a vice, and remove the Bolt (18) with a wrench.

The valve unit (Lever (4), Valve Seat (5), Valve (6), Holder (7), Lever Nut (8), Nut (9), Connector (10), Nut (11), Guide Wing (12), Pin (13), Baffle Plate (14), Nut (15)) comes apart. The Float (3) and the Air Vent (21) can be removed with a wrench.

B. Cleaning, checking, repairing

- (1) After "A" is removed, clean and check (repair if needed) each part.
- (2) If the Float (3) is damaged, loosen the Nut (15) of the Lever (4), and unscrew the Float (3) by hand and then replace it.
- (3) If the Valve (6) and Valve Seat (5) are worn or defected, replace the whole valve unit.

C. Re-assemble the body

- (1) After cleaning, checking (repairing if needed) the trap, re-assemble the parts in reverse order.
- (2) Replace the Gaskets (16), (17), (24) to new ones at each maintenance.
Gaskets (16), (17), (24) are fragile, so please handle them with care.
- (3) Bolt (18), Bolt (19), (25) should be tightened evenly.

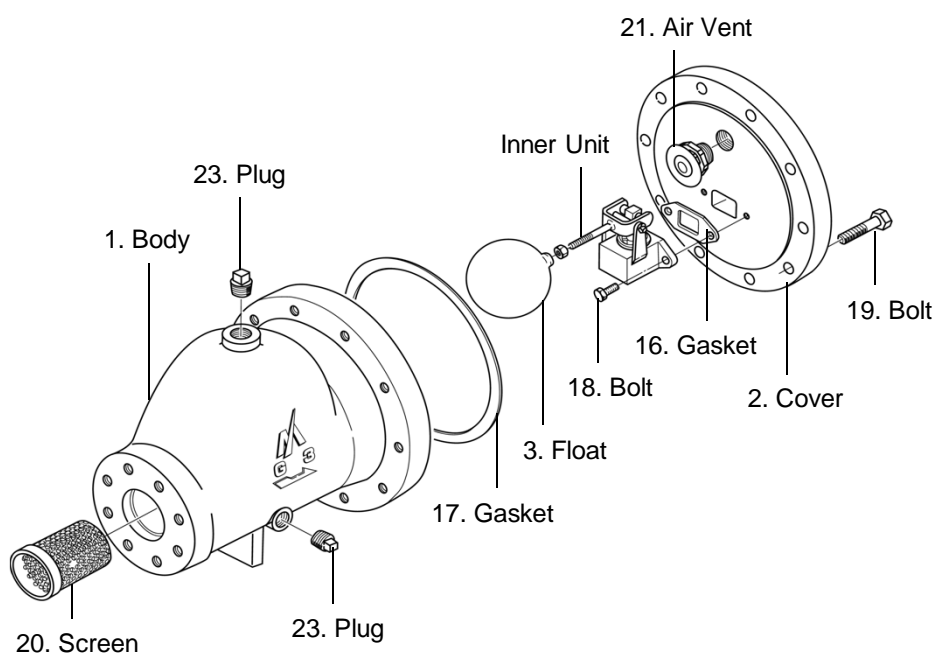

*The clamp torque of the screws will be as per the following chart.

Torque table 1

MODEL	PART NO	PART	ACROSS THE FLATS	CLAMP TORQUE
G3N G3N-R	18	Bolt	14 mm (0.56 inch)	30N·m (300 kgf·cm)
	19	Bolt	17 mm (0.68 inch)	40N·m (400 kgf·cm)
	21	Air Vent	32 mm (1.28 inch)	130 N·m (1,300 kgf·cm)
	25	Bolt	24 mm (0.96 inch)	80N·m (800 kgf·cm)
G5 G5-R	18	Bolt	17 mm (0.68 inch)	40 N·m (400 kgf·cm)
	19	Bolt	22 mm (0.88 inch)	60 N·m (600 kgf·cm)
	21	Air Vent	32 mm (1.28 inch)	130 N·m (1,300 kgf·cm)
	25	Bolt	24 mm (0.96 inch)	80N·m (800 kgf·cm)

7 TROUBLESHOOTING

Problem	Possible Causes	Solution
Steam blows through	Float is damaged.	Replace the float.
	Valve is fallen off.	Restore the valve.
	Damage, wear or corrosion of the valve and/or the valve seat.	Replace the valve and/or the valve seat.
	Stuck valve or dirt accumulated around valve or valve seat.	Clean the valve and/or the valve seat.
	Automatic Air Vent is failed.	Repair or replace the Automatic Air Vent.
Steam leaks from the body	Bolts are loose.	Tighten the bolts.
	Gasket is damaged or worn.	Replace the gasket.
	The sealing surface on the body or the cover is damaged.	Replace the body or the cover
Insufficient condensate discharged, or no condensate discharged	Air binding.	Check if the Automatic Air Vent failed.
	Float locates incorrectly.	Locate the Float correctly.
	Float is damaged or filled up with water.	Replace the Float.
	Orifice of valve seat is clogged.	Clean the Valve Seat.
	Screen is clogged.	Clean the Screen.
	Pressure is too high.	Change the pressure or replace the trap with an appropriate one.
	Insufficient capacity of condensate.	Replace the trap with a larger capacity.

* See the torque table in Chapter 6.

8 LIMITED WARRANTY

Any trap that fails in normal operating conditions will be repaired free of charge.

WARRANTY TERM

This warranty term shall be for the first 12 months of ownership, starting from the date of delivery to you.

WHAT THIS WARRANTY DOES NOT COVER

- (1) Damage caused by careless use or ignoring the warnings and cautions given in this manual.
- (2) Damage caused by severe shock or an impact which would not be experienced in normal operation.
- (3) Damage caused by unauthorized modifications or repairs.
- (4) Damage caused by fire, natural disasters, or acts of God.
- (5) Damage caused by inappropriate handling or installation in a way that violates the specifications.
- (6) Damage caused by equipment, apparatus or devices that are not provided by MIYAWAKI.
- (7) Damage caused by chlorine, or other materials that are corrosive to metals or hasten deterioration.
- (8) Damage caused by a part such as a gasket that is severely deteriorated.
- (9) Damage caused by accumulated dirt or debris on or around the seat.

WARRANTY SCOPE

In any event, the scope of the warranty is limited to compensation that does not exceed the purchase price of the product.