

Flow-Tek®

Subsidiary of BRAY INTERNATIONAL, Inc.

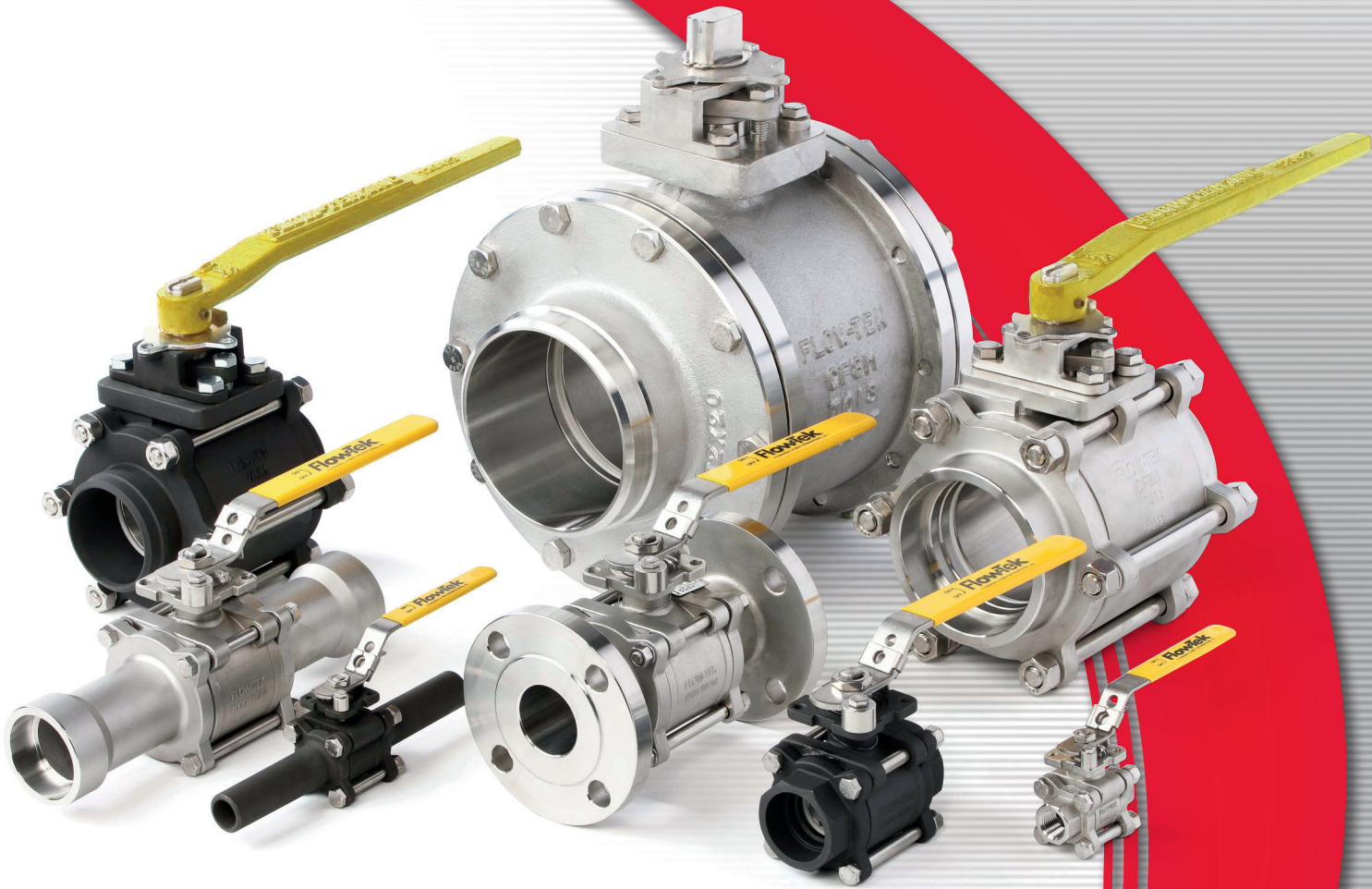

SERIES 7000/8000

3 PIECE FULL PORT 1/4" - 12"

7000 - SS | 8000 - CS

1/4" - 4" 1,000 psi WOG

6" - 12" 400 psi WOG

7000/8000 SERIES BALL VALVES

Flow-Tek's Series 7000 and 8000 ball valves offer the highest flexibility in selection of end connections, seat materials in a 3-piece design. To meet customer demands for a valve with the widest possible range of applications, these valves can be fitted with control or tri-ported balls (for full cavity drainage), as well as cavity fillers for special service requirements.

The Series 7000/8000 is designed with extensive interchangeability of balls, stems, stem packing, handles and mounting hardware between valve sizes and series members. This system reduces parts inventory and maintenance costs.

The 3-piece body design allows the body to swing-out for ease of in-line maintenance. It also makes it possible to offer a wide variety of end connections.

BALL - Flow-Tek balls are solid metal, precision machined and mirror finished for bubble-tight shut off with less operating torque. Ball edges have machined curvatures to reduce seat wear and provide a high cycle life.

BODY - Valve bodies are investment cast and solution annealed/normalized for the highest quality and added strength. Body castings are marked with a foundry heat number for full traceability. Carbon steel bodies are phosphate coated for increased corrosion resistance.

SEAT - Flow-Tek's seat design ensures bi-directional, bubble-tight sealing while providing the lowest possible torque. This seat design reduces friction, minimizes seat wear and reduces operating torque.

SEAT MATERIALS - Flow-Tek offers the following standard seat materials for the Series 7000/ 8000: RPTFE, TFM-1600, Stainless Steel/PTFE (50/50), UHMWPE, Virgin PTFE, Tek-Fil®, and Cavity Fillers. Other seat materials are available.

DOUBLE LOCK NUT DESIGN - Standard on the Series 7000/8000, the double lock nuts allow handles to be easily and safely removed while the valve is under full line pressure.

LIVE-LOADED STEM SEALS - The standard (up to 2½") live-loaded stem seals with Belleville washers considerably increase the number of cycles between maintenance adjustments.

SECURE MOUNT The integrally cast top flange ensures positive actuator mounting. Secure Mount eliminates unwanted actuator movement during high cycle or continuous duty applications. Actuation equipment can be easily and safely removed while the valve is under full line pressure. Designed to ISO 5211 bolting pattern standards.

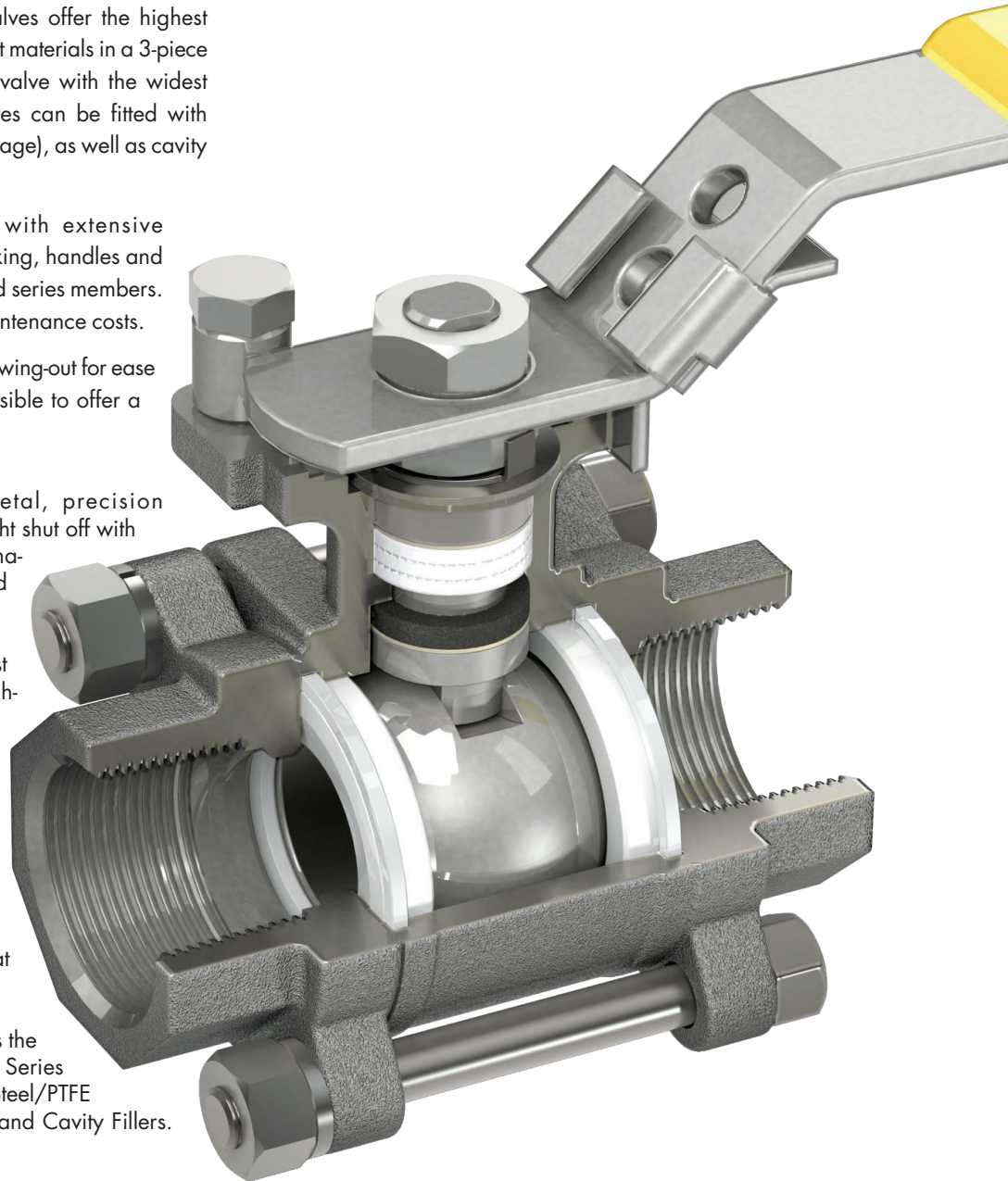

HANDLE Flow-Tek handles feature a standard Safety Trigger to prevent accidental movement of ball position. Operation is easily made with one hand. The trigger locks the handle in the open or closed position. The handle lock can be bypassed, if needed, with a small bolt through the handle in the bypass position. An Anti-Tamper Padlock can be used to secure the handle in position, preventing unwanted access. Travel stops limit the movement of handle to set 90° intervals, preventing over travel of the ball.

END CONNECTIONS - Full range of interchangeable connections including threaded, socket weld, butt weld, ASME Class 150 flanged and extended weld in place.

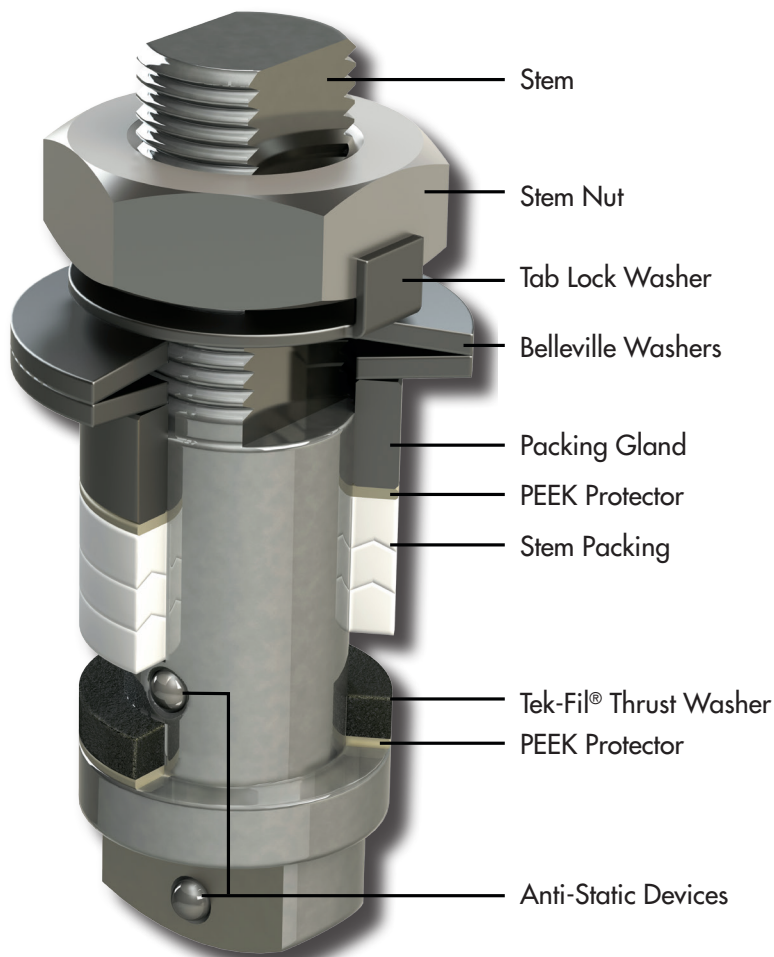

SMART STEM - Valve Sizes 1/4" through 2 1/2"
 Flow-Tek's interchangeable family of valves feature strong large diameter stems with live-loaded, self-adjusting stem seal utilizing Belleville washers which automatically adjust to compensate for changes in temperature and wear. The assembly is secured by a saddle-type tab lock washer which prevents stem nuts from unthreading in high cycle automation applications.

STEM ASSEMBLIES - Flow-Tek manufactures heavy duty, high quality stems with double "D" connection to ball and operator mounting. Stems are mated with the ball to ensure positive contact. All Flow-Tek stems are internal entry and blow-out proof for maximum safety. 2 1/2", 3" and 4" valves feature a NAMUR stem slot for ease of limit switch mounting.

STEM PACKING - An adjustable V-ring design creates a multiple seal between the stem and body. Each stem assembly is composed of three or four (dependent on valve size) rings providing a very high cycle life by resisting creep and cold flow. The Thrust Washer and the Thrust Washer Protector combine to provide a primary seal, reduce torque and prevent galling.

ANTI-STATIC PROTECTION - Series 7000/8000 valves feature anti-static grounding devices as standard. These devices ensure electrical continuity between valve ball, stem and body, thus eliminating the possibility of static electrical charges creating sparks within the valve.

STEM DESIGN FOR 3" - 12" VALVES - The stem is guided by the valve body and the gland, ensuring smooth operation even in high torque service. The packing gland is adjustable and all stems are polished to reduce torque. Optional Belleville washers can be added for a self-adjusting, live loaded stem packing assembly.

PRESSURE RATINGS

Threaded, Socket Weld and Butt Weld:	Sizes 1/4" - 4"	1000 psi WOG
	Sizes 6" - 12"	400 psi WOG
Flanged:	ASME B16.34 Class 150	
Steam Rating:	150 WSP TFM	
	425 WSP Tek-Fil	
Vacuum Rating:	29.9 in. Hg gauge	

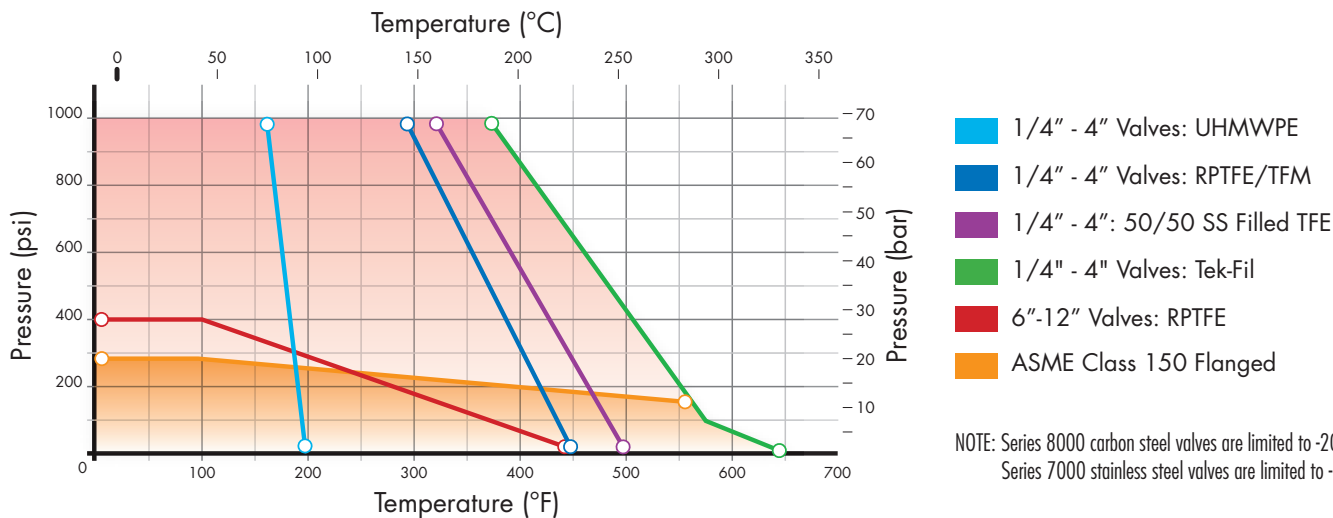

NOTE: Series 8000 carbon steel valves are limited to -20°F.
 Series 7000 stainless steel valves are limited to -50°F.

SPECIAL OPTIONS/SERVICES

Cavity Fillers
 Deadman Handles
 Vented Balls
 Chlorine Service
 Polished Internals
 Special Cleaning
 Silicone Free

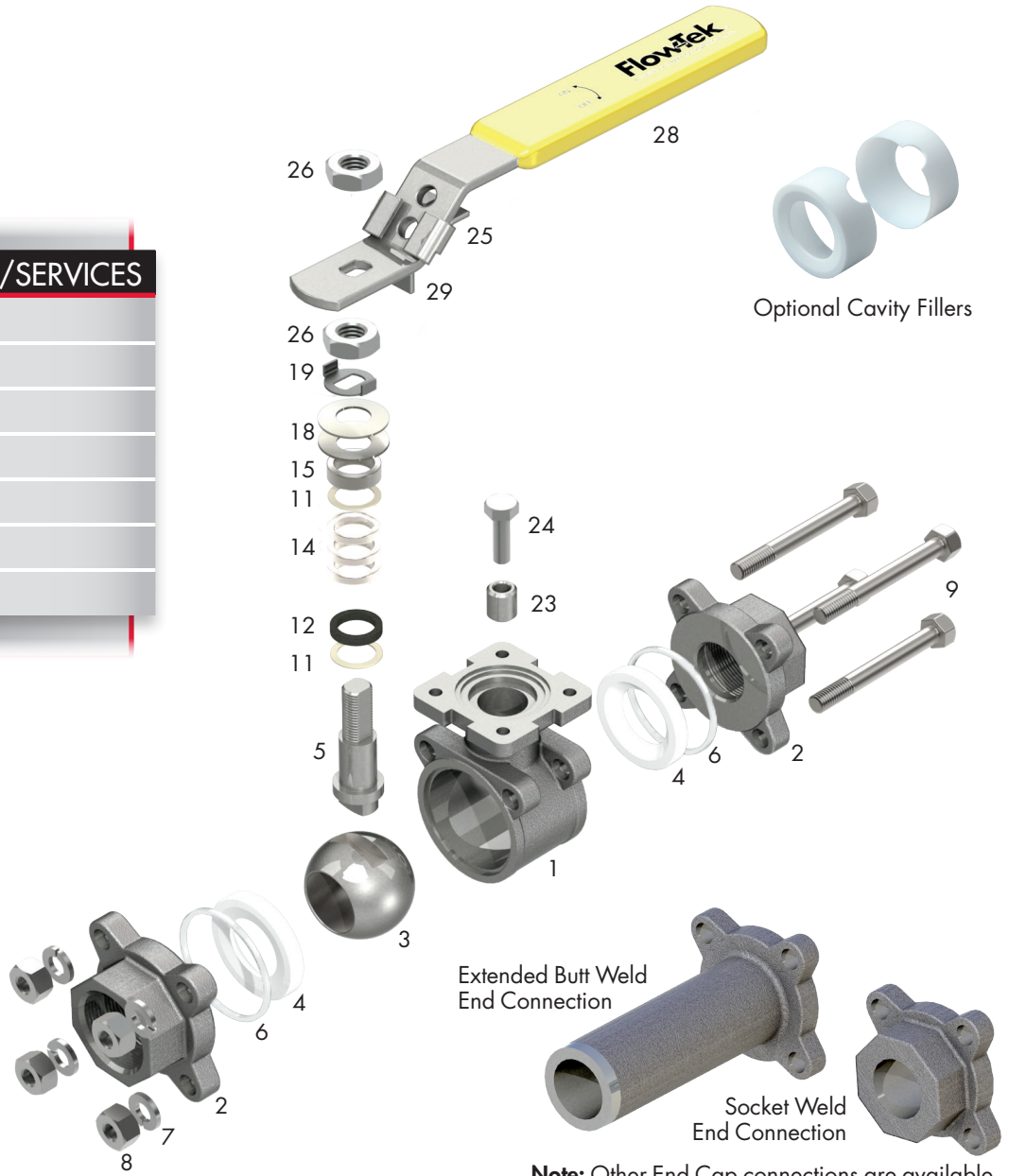

Extended Butt Weld
 End Connection

Socket Weld
 End Connection

Note: Other End Cap connections are available.

COMPONENTS AND MATERIALS – 1/4" to 2 1/2"

ITEM/NAME	STAINLESS STEEL	CARBON STEEL	QTY.
1 Body	ASTM A351 Gr CF8M	ASTM A216 Gr WCB	1
2 End Cap*	ASTM A351 Gr CF8M*	ASTM A216 Gr WCB	2
3 Ball	ASTM A351 Gr CF8M		1
4 Seat	15% RPTFE		2 •
5 Stem	ASTM A479 Type 316		1
6 Body Seal	TFM		2 •
7 Spring Lock Washer	SS304		†
8 Body Nut	SS304		†
9 Body Bolt / Stud	SS304		4
10 Anti-Static Device (not shown)	SS316		2
11 Thrust Washer/Packing Protector	PEEK		2 •

ITEM/NAME	STAINLESS STEEL	CARBON STEEL	QTY.
12 Thrust Washer	TEK-FIL		1 •
14 Stem Packing	15% RPTFE		3 •
15 Packing Gland Sleeve	SS304		1
18 Belleville Washer	SS301		2
19 Tab Lock Washer	SS304		1
23 Travel Stop Set Sleeve	SS304		1
24 Travel Stop Bolt	SS304		1
25 Handle	SS304		1
26 Stem Nut	SS304		2
28 Handle Sleeve	Vinyl		1
29 Locking Device	SS304		1

* Weld Ends use CF3M

† Number of Nuts and Spring Washers: 1/4" to 2" Valves – 4; 2 1/2" Valves – 8

• Recommended spare parts that are available as a packaged repair kit

SPECIFICATIONS

Valve Sizes 1/4" through 12"

Design meets MSS-SP-110.

Threaded End Connections meet
ASME B1.20.1 NPT.

Socket Weld End Connections meet
ASME B16.11.

Butt Weld End (sch 40) Connections meet
MSS SP-72 / ASME B16.25.

Flanged End Connections meet
ASME Class 150.

Valve body and end cap connections are
high quality investment cast and solution
annealed/normalized. Body and end
cap wall thickness meets ASME B16.34.

Valve stems are blow-out proof for
maximum safety and meet ASME B16.34
specification.

All valves are factory tested to
MSS SP-72 and API 598.

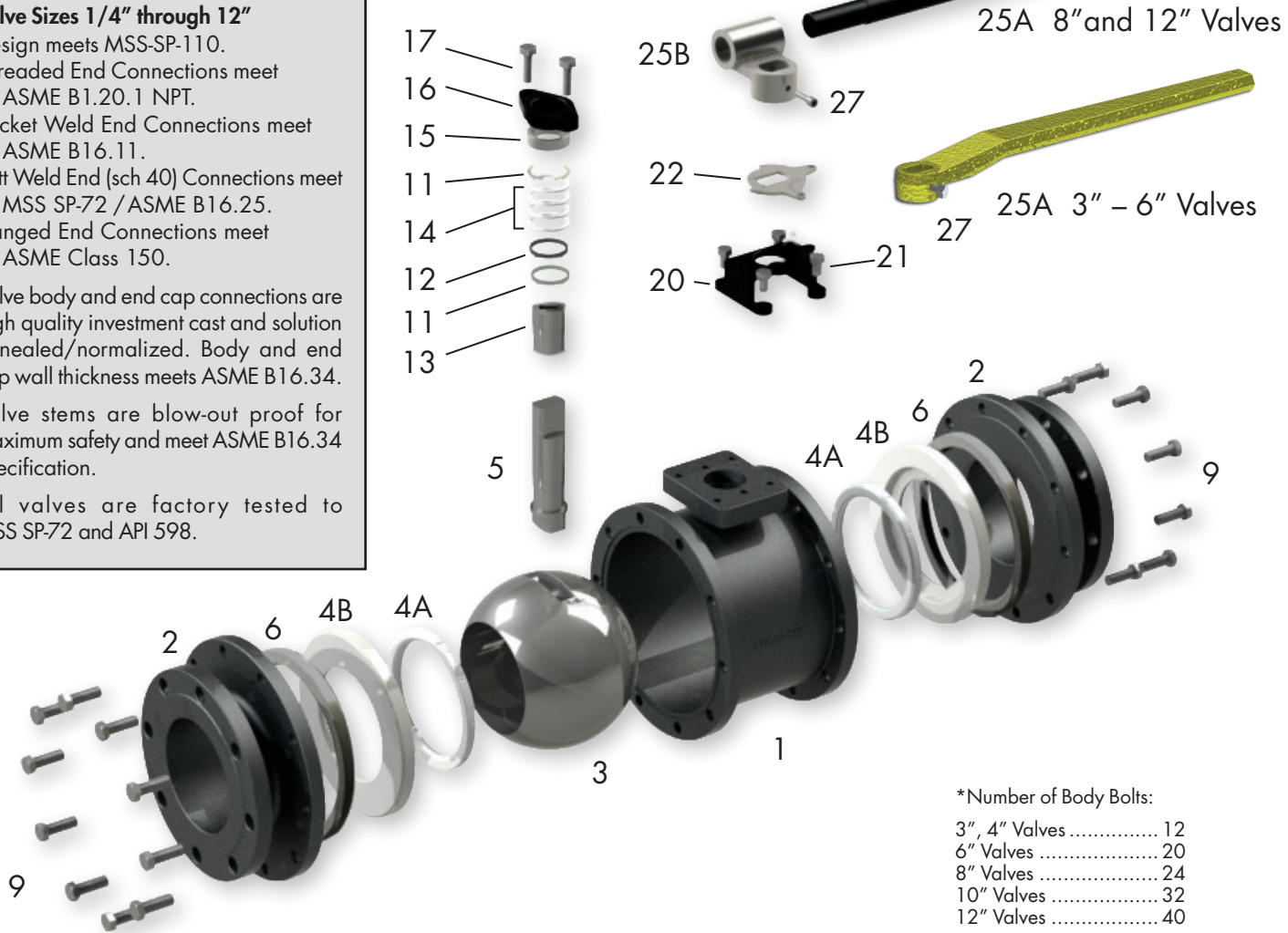

*Number of Body Bolts:

3", 4" Valves	12
6" Valves	20
8" Valves	24
10" Valves	32
12" Valves	40

COMPONENTS AND MATERIALS – 3" - 12"

ITEM / NAME	STAINLESS STEEL	CARBON STEEL	QTY
1 Body	ASTM A351 Gr CF8M	ASTM A216 Gr WCB	1
2 End Cap†	ASTM A351 Gr CF8M†	ASTM A216 Gr WCB	2
3 Ball	ASTM A351 Gr CF8M		1
4A Seat	15% RPTFE		2 •
4B Seat Support	ASTM A351 Gr CF8M	ASTM A216 Gr WCB	2††
5 Stem	ASTM A479 Type 316		1
6 Body Seal	PTFE		2 •
9 Body Bolt	SS304		*
10 Anti-Static Device (not shown)	SS316		2
11 Thrust Washer/ Packing Protector	PEEK		2 •
12 Thrust Washer	TEK-FIL		1 •

† Weld Ends use CF3M

†† Seat Supports for 6" and larger valves

††† 3 or 4 rings depending on valve size

ITEM / NAME	STAINLESS STEEL	CARBON STEEL	QTY
13 Stem Bearing	15% RPTFE		1 •
14 Stem Packing	15% RPTFE		4 •†††
15 Packing Gland	SS304	Carbon Steel	1
16 Packing Follower	ASTM A351 Gr CF8M	ASTM A216 Gr WCB	1
17 Gland Bolt	SS304	Carbon Steel	2
20 Stop Housing	ASTM A351 Gr CF8M	ASTM A216 Gr WCB	1
21 Housing Bolt	SS304	Carbon Steel	4
22 Travel Stop	SS304	Carbon Steel, Zinc Plated	1
25A Handle	Ductile Iron/Carbon Steel		1
25B Handle Junction	Ductile Iron		1
27 Handle Bolt	Carbon Steel		2
30 Snap Ring (not shown)	Nickel Plated Carbon Steel		1

• Recommended spare parts that are available as a packaged repair kit

SERIES 7000 & 8000 DIMENSIONS 1/4" - 12" VALVES (8mm - 300mm)

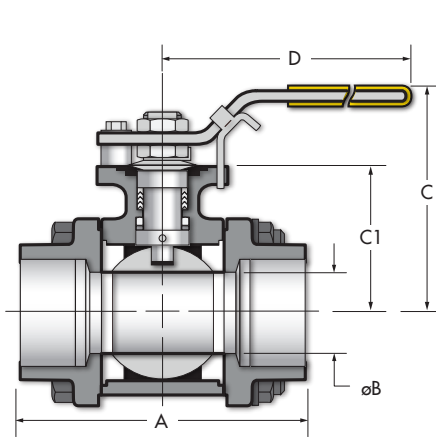

1/4" - 2 1/2" VALVES

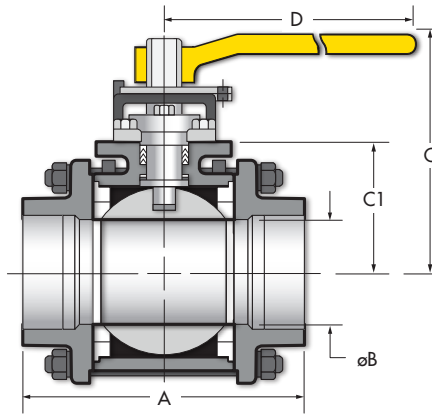

3" - 4" VALVES

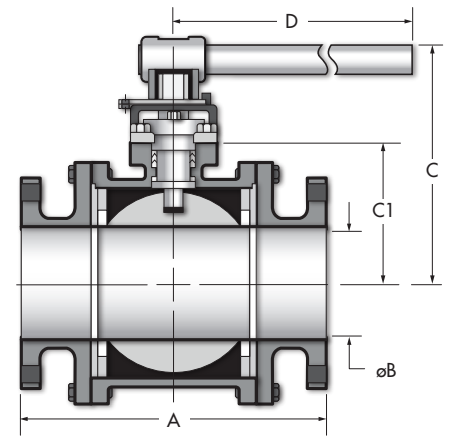

6" - 12" VALVES

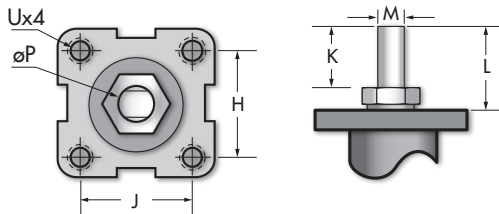

Secure Mount: 1/4" - 2 1/2" VALVES

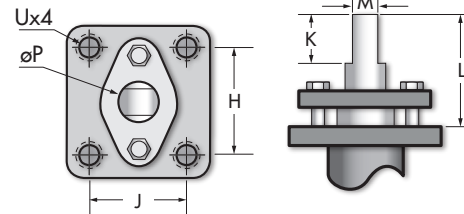

Secure Mount: 3" - 12" VALVES

DIMENSIONS – Models 7000 (316SS) / 8000 (WCB)

SIZE	A				øB	C	C1	D	H	J	K	L	M	P	U (UNC)
	NPT, SW, BW	FLG	Extended SW	Extended BW											
1/4	2.84	—	—	—	0.37	2.60	1.54	6.50	1.17	1.17	0.32	0.55	0.25	0.37	10-24
3/8	2.84	—	—	—	0.50	2.60	1.54	6.50	1.17	1.17	0.32	0.55	0.25	0.37	10-24
1/2	2.84	4.39	10.04	9.04	0.59	2.60	1.54	6.50	1.17	1.17	0.32	0.55	0.25	0.37	10-24
3/4	3.35	5.80	10.43	9.30	0.79	2.91	1.66	6.50	1.17	1.17	0.32	0.55	0.25	0.37	10-24
1	3.62	5.97	10.71	9.48	1.00	3.43	2.05	7.87	1.39	1.39	0.43	0.75	0.32	0.43	1/4-20
1 1/4	4.33	—	11.21	9.84	1.26	3.62	2.21	7.87	1.39	1.39	0.43	0.75	0.32	0.43	1/4-20
1 1/2	4.84	8.03	11.78	10.28	1.50	4.13	2.60	9.84	1.95	1.95	0.55	0.91	0.37	0.62	5/16-18
2	5.59	9.04	12.48	10.73	2.00	4.53	2.95	9.84	1.95	1.95	0.55	0.91	0.37	0.62	5/16-18
2 1/2	7.26	—	—	12.00	2.56	5.04	3.39	9.84	2.84	2.84	0.69	1.14	0.47	0.75	5/16-18
3	7.95	10.10	—	12.00	2.99	6.42	3.72	15.35	3.54	1.87	1.75	3.07	0.67	1.10	1/2-13
4	9.06	13.90	—	12.00	4.02	7.087	4.35	15.35	3.54	1.87	1.75	3.07	0.67	1.10	1/2-13
6	18.00	15.50	—	—	5.98	12.21	7.17	43.31	3.38	3.38	1.65	3.54	1.02	1.71	1/2-13
8	20.50	18.00	—	—	7.87	13.50	8.47	43.31	3.38	3.38	1.65	3.54	1.02	1.71	1/2-13
10	22.00	21.00	—	—	9.84	14.69	9.96	43.31	4.53	4.53	1.97	3.78	1.38	2.17	5/8-11
12	25.00	24.00	—	—	11.81	16.26	11.54	43.31	4.53	4.53	1.97	3.78	1.38	2.17	5/8-11
8	72.1	—	—	—	9.5	66	39	165	29.7	29.7	8	14	6.4	9.3	10-24
10	72.1	—	—	—	12.7	66	39	165	29.7	29.7	8	14	6.4	9.3	10-24
15	72.1	111.5	254.9	229.5	15	66	39	165	29.7	29.7	8	14	6.4	9.3	10-24
20	85	147.2	264.8	236.2	20	74	42.1	165	29.7	29.7	8	14	6.4	9.3	10-24
25	92	151.7	271.9	240.7	25.4	87	52	200	35.7	35.7	11	19	8	10.9	1/4-20
32	110	—	284.8	249.8	32	92	56	200	35.7	35.7	11	19	8	10.9	1/4-20
40	123	204	299.2	261	38	105	66	250	49.5	49.5	14	23	9.5	15.7	5/16-18
50	142	229.6	317	272.6	50.8	115	75	250	49.5	49.5	14	23	9.5	15.7	5/16-18
65	184.5	—	—	304.8	65	128	86	250	72.1	72.1	17.5	29	12	19	5/16-18
80	202	256.5	—	304.8	76	163	94.5	390	90	47.6	44.5	78	17	28	1/2-13
100	230	353	—	304.8	102	180	110.5	390	90	47.6	44.5	78	17	28	1/2-13
150	457.2	394	—	—	152	310	182	1100	85.7	85.7	42	90	26	43.5	1/2-13
200	520.7	457	—	—	200	343	215	1100	85.7	85.7	42	90	26	43.5	1/2-13
250	558.8	533	—	—	250	373	253	1100	115	115	50	96	35	55	5/8-11
300	635	610	—	—	300	413	293	1100	115	115	50	96	35	55	5/8-11

Note: Flanged Face-Face dimension on sizes 1/2" through 4" are manufacturer's standard; 6" through 12" meet ASME B16.10 long pattern

SERIES 7000 & 8000 DIMENSIONS 1/4" – 12" VALVES (8mm - 300mm)

Flow-Tek's 3 piece valve is offered with a center body and a large selection of end connections. This versatile design offers easy customizing to meet most special application requirements.

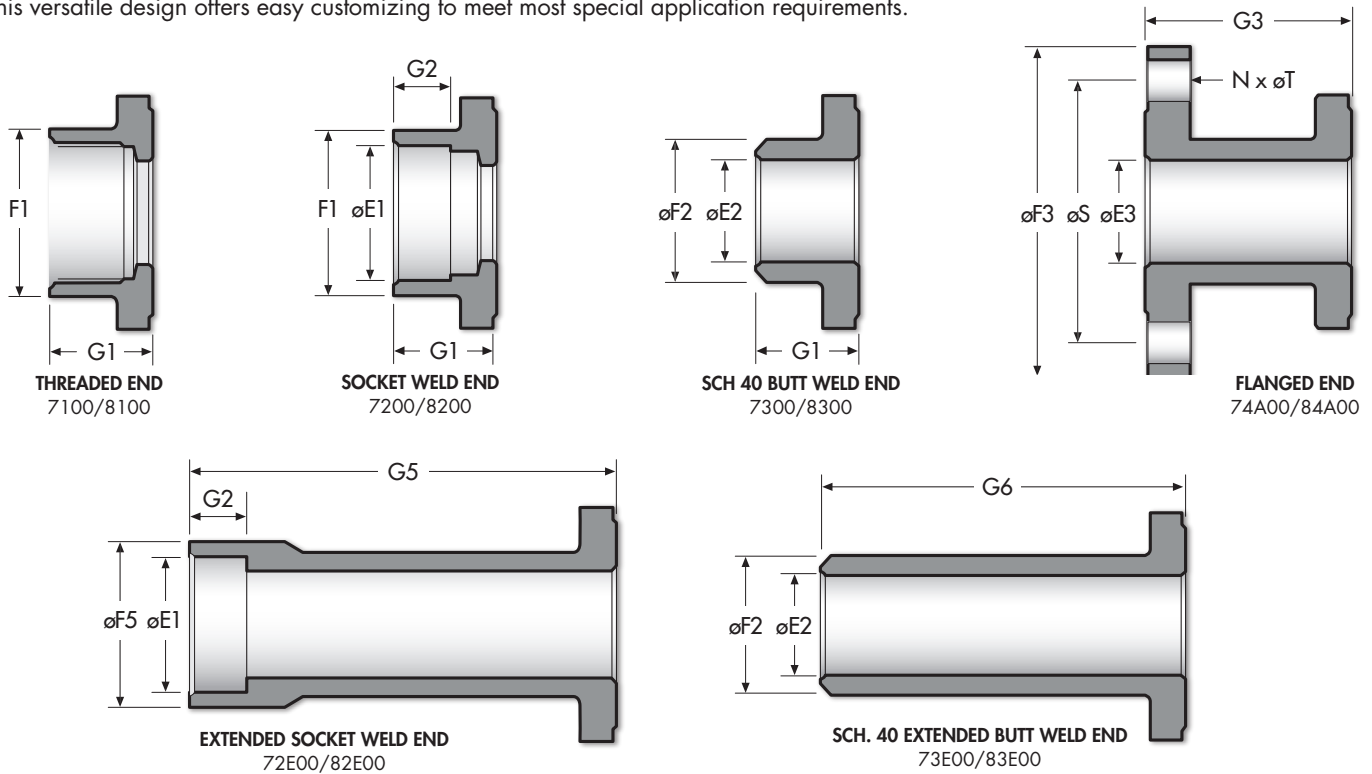

Extended End connections may be fabricated from pipe and fittings.

DIMENSIONS – Models 7000 (316SS) / 8000 (WCB)																	VALVE		
SIZE	E1	E2	E3	F1	F2	F3	F5	G1	G2	G3	G5	G6	N	S	T	Cv	TORQUE	WEIGHT	
INCHES	1/4	0.55	0.36	—	0.98	0.54	—	0.90	0.500	—	—	—	—	—	—	8	60	1.8	
	3/8	0.69	0.49	—	0.98	0.68	—	0.90	0.500	—	—	—	—	—	—	8	60	1.8	
	1/2	0.85	0.62	0.57	1.10	0.84	3.50	1.14	0.90	0.500	1.67	4.50	4.00	4	2.38	0.62	32	60	1.8
	3/4	1.07	0.82	0.79	1.39	1.05	3.88	1.46	1.02	0.560	2.24	4.56	4.00	4	2.75	0.62	54	95	2.3
	1	1.33	1.05	0.98	1.65	1.32	4.25	1.77	1.07	0.63	2.24	4.61	4.00	4	3.12	0.62	105	140	3.4
	1 1/4	1.67	1.38	—	2.05	1.66	—	2.17	1.24	0.69	—	4.69	4.00	—	—	—	200	195	4.9
	1 1/2	1.91	1.61	1.50	2.36	1.90	5.00	2.44	1.28	0.75	2.87	4.75	4.00	4	3.88	0.62	275	315	7.6
	2	2.41	2.07	2.00	2.91	2.38	6.00	2.91	1.43	0.87	3.15	4.87	4.00	4	4.75	0.75	500	510	11.4
	2 1/2	2.91	2.46	—	3.39	2.87	—	—	1.95	0.98	—	—	—	—	—	—	780	800	21.8
	3	3.54	2.99	2.99	4.17	3.62	7.50	—	1.97	0.98	3.04	—	—	4	6.00	0.75	1,150	1,100	34.6
	4	4.54	4.02	3.40	5.32	4.78	9.00	—	2.09	1.18	4.51	—	—	8	7.50	0.75	2,100	3,600	54.7
	6	—	6.07	5.98	—	6.63	11.0	—	4.87	—	3.62	—	—	8	9.50	0.88	5,000	4,150	233.7
8	—	7.98	7.87	—	8.63	13.5	—	5.23	—	3.98	—	—	8	11.75	0.88	9,600	6,200	377	
10	—	10.02	9.84	—	10.75	16.0	—	4.94	—	4.43	—	—	12	14.25	1.00	15,000	14,700	632.7	
12	—	11.94	11.81	—	12.75	19.0	—	5.14	—	4.65	—	—	12	17.00	1.00	21,000	22,000	CF	
MILLIMETERS	8	14	9.25	—	25	13.7	—	22.8	12.7	—	—	—	—	—	—	8	6.8	0.8	
	10	17.5	12.5	—	25	17.2	—	22.8	12.7	—	—	—	—	—	—	8	6.8	0.8	
	15	21.7	15.8	14.4	28	21.3	88.9	29	22.8	12.7	42.5	114.2	101.5	4	60.5	15.6	32	6.8	0.8
	20	27.1	20.93	20	35	26.7	98.6	37	25.9	14.3	57	115.8	101.5	4	69.9	15.6	54	10.7	1.1
	25	33.8	26.6	25	42	33.4	107	45	27.1	15.9	57	117.1	101.5	4	79.3	15.6	105	15.8	1.5
	32	42.6	35.1	—	52	42.2	—	55	31.6	17.5	—	119	101.5	—	—	—	200	22.0	2.2
	40	48.6	40.9	38	60	48.3	127	62	32.5	19.1	73	120.6	101.5	4	98.6	15.6	275	35.6	3.5
	50	61.1	52.5	50.8	74	60.3	152.4	74	36.2	22.2	80	123.7	101.5	4	120.7	19.1	500	57.6	5.2
	65	73.8	62.5	—	86	73	—	—	49.5	25	—	—	—	—	—	—	780	90.4	9.9
	80	89.8	76	76	106	92	190.5	—	50	25	77.3	—	—	4	152.4	19.1	1,150	124.3	15.7
	100	115.4	102	101.5	135	121.5	228.6	—	53	30	114.5	—	—	8	190.5	19.1	2,100	406.7	24.8
	150	—	154.1	152	—	168.3	279.4	—	123.6	—	92	—	—	8	241.3	22.4	5,000	469	106
	200	—	202.7	200	—	219.1	342.9	—	132.9	—	101	—	—	8	298.5	22.4	9,600	700.5	171
	250	—	254.5	250	—	273.1	406.4	—	125.4	—	112.5	—	—	12	362	25.4	15,000	1,661	287
	300	—	303.2	300	—	323.6	482.6	—	130.5	—	118	—	—	12	431.8	25.4	21,000	2,486	CF

Note: 1/4"-4" weights are based on threaded end connection.
6"-12" weights are based on Class 150 flanged ends.
Torque values are at maximum rated pressures, clean water, RPTFE seats.
Refer to Tech Bulletin 1005 for complete torque information.

For Cam Lock, Tube O.D. and Flush Bottom Tank connection dimensions and for other available End Connections, please consult the Flow-Tek factory. End connections are fully interchangeable and can be used in any combination.

7000/8000 SERIES BALL VALVES

3 PIECE VALVE BODY DESIGN

The unique body design of the Series 7000/8000 offers many advantages, including installation flexibility, and ease of in line and out of line servicing. These time saving features are a big plus for process industries, automated valves and welded piping systems by reducing costly downtime. Heavy duty hinges, throughout the entire

size range, provide positive alignment of body to end connection during swing-out, in-line servicing. During maintenance, the actuator and mounting assemblies remain on the valve body. The entire valve and actuator assembly is easily reinstalled. No actuator adjustment or reattachment is necessary.

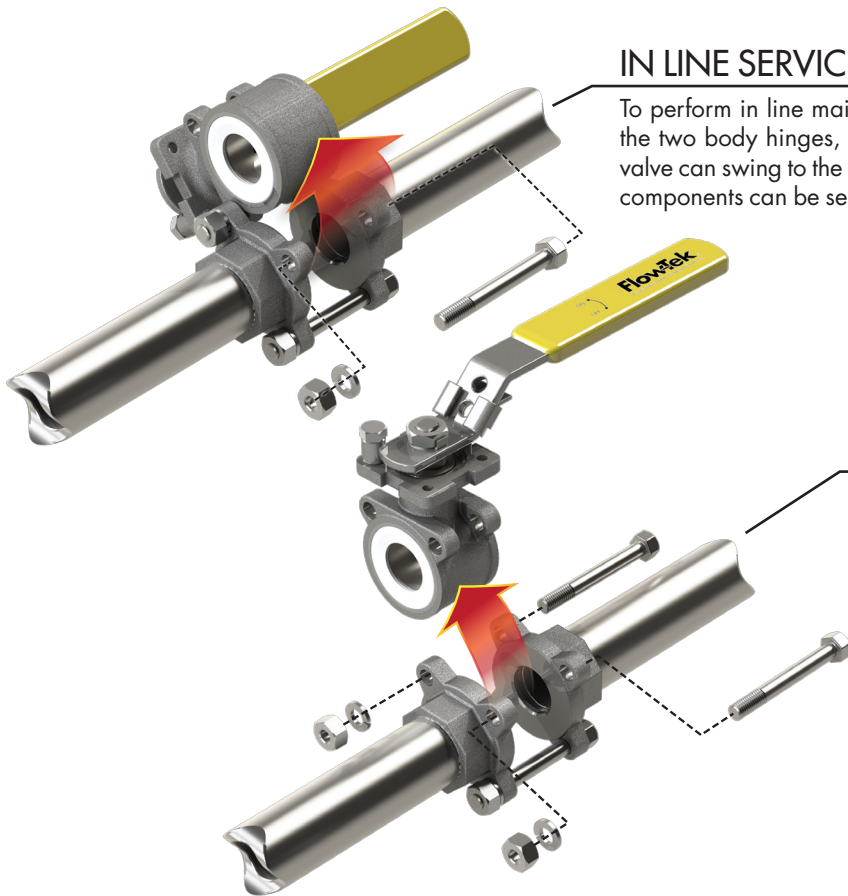

IN LINE SERVICING

To perform in line maintenance, remove one of the body bolts through one of the two body hinges, loosen the remaining bolts and swing the body up. The valve can swing to the left or right depending on which bolt is removed. All body components can be serviced in this position without disturbing the pipe system.

OUT OF LINE SERVICING

For complete removal of valve from the line, remove the upper two bolts that go through the body hinges, loosen the lower two while keeping them in line, then lift the valve body out of the pipeline. The remaining two bolts help to keep the pipeline system in place and maintain alignment. The removed body can then be serviced and/or replaced.

3 PIECE WELD IN PLACE SERIES

Socket-Weld and Butt-Weld

Flow-Tek offers extended end connections for the Series 7000/8000 valves. These ends allow the customer to weld the valve in the piping system without valve and/or actuator disassembly possibly damaging the seat or seals. Installation time and piping material is reduced. Additionally, the Weld In Place Series extended end connections limit potential installation errors. The valve is factory assembled and tested, then delivered to the customer for installation.



Flow-Tek®

Subsidiary of BRAY INTERNATIONAL, Inc.
8323 N. Eldridge Pkwy #100 Houston, Texas 77041
832.912.2300 Fax: 832.912.2301
www.flow-tek.com

All statements, technical information, and recommendations in this bulletin are for general use only. Consult Flow-Tek representatives or factory for the specific requirements and material selection for your intended application. The right to change or modify product design or product without prior notice is reserved.

Flow-Tek® is a registered trademark of Flow-Tek, Inc.
© 2015 Flow-Tek, Inc.
F-2301_EN_S7K-8K_10_2015