

**BALL FLOAT STEAM TRAP**

# **GH2 / GH4 / GH6 / GH8**

## **USER'S MANUAL**

- 1. SYMBOL USED**
- 2. SAFETY INSTRUCTIONS**
- 3. SPECIFICATIONS**
- 4. NAMES OF  
COMPONENTS AND PARTS**
- 5. INSTALLATION**
- 6. MAINTENANCE**
- 7. TROUBLESHOOTING**
- 8. LIMITED WARRANTY**

**Be sure to read this manual to learn the safe and proper operation of this product.  
Store this manual carefully after use.**



## To the owner

Ball Float Steam Trap Model GH series is designed for large capacities with built in bi-metal air vent and double ported balance valve. In order to get maximum benefit from this product, be sure to read this manual before installing it.

## Maintenance

If this product functions or looks abnormal, take the necessary steps to correct it.

If it seemingly cannot be corrected, ask your MIYAWAKI dealer what to do and give him the following information.

- (1) Model
- (2) Serial (S)/ No.
- (3) Detailed description of the abnormal condition.

## Supply Period for Maintenance Parts

We will continue to supply maintenance parts for this product for 5 years after we discontinue production of the primary product.

The supply of maintenance parts will, in principle, terminate at the end of the supply period stated above. However, even after the supply period has run out, it is possible to consult with us about the delivery time and prices for parts that are still in stock.

# 1 SYMBOLS USED

## ●SYMBOL INDICATION



### (1) Safety-alert Symbol

This is the safety-alert symbol. When this symbol is on the machine or in this manual, be alert to the possibility of personal injury and carefully read the messages that follow.

### (2) Signal Words

The signal words "WARNING", "CAUTION" are used with the safety-alert symbol.



**WARNING**

WARNING denotes an extreme hazard which will likely result in death or serious personal injury if proper precautions are not taken.



**CAUTION**

CAUTION denotes general precautions that may result in injury or damage to objects if proper precautions are not taken.

## 2 SAFETY INSTRUCTIONS

Observe the following instructions to insure safe operation. If you don't, you may be seriously injured and the product may be damaged.

- \* Be sure not to use this product at a pressure higher than the specified maximum operating pressure (PMO) or at a temperature higher than the specified maximum operating temperature (TMO).
- \* Pay very careful attention when working in hazardous environments such as: There is a risk of explosion and the possibility of dangerous gasses leaking.
- \* Always check whether the pipeline contains flammable, high pressure or high temperature materials before starting to work.
- \* Make sure that isolation valves are installed on both the upstream and downstream lines.
- \* Before installing the product, open the isolation valves, and the bypass valve, if one exists, to blow out any debris or dust inside the pipeline.
- \* When installing the product, be sure to leave clearance for maintaining it.
- \* When replacing parts, make sure the replacement parts are supplied by MIYAWAKI.

## 3 SPECIFICATIONS

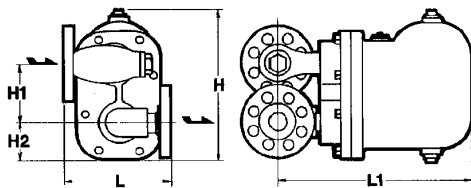

**GH2**

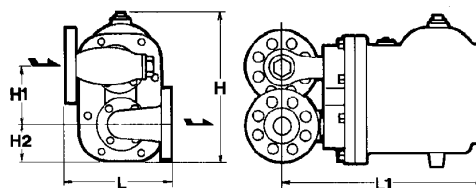

**GH4/GH6/GH8**

MODEL NO.	CONNECTION		BODY MATERIAL	OPERATING PRESSURE MPa (psig)	MAX. TEMP. °C(°F)	DIMENSIONS mm (inch)					WEIGHT kg (lb)
	TYPE	SIZE mm (inch)				L	L1	H	H1	H2	
GH2		25 (1")	Cast Steel (SCPH2)	0.01~2.0 (1.45~290)	400 (752)	200 (7.9)	310 (12.2)	235 (9.4)	83 (3.3)	65 (2.6)	24 (52.8)
		32 (1-1/4")				200 (7.9)					
		40 (1-1/2")				200 (7.9)					
		50 (2")				210 (8.3)					
GH4	Flanged	32 - 50 (1-1/4" - 2)				200 (7.9)	380 (15.2)	320 (12.8)	105 (4.1)	90 (3.5)	43 (94.6)
GH6		40 - 80 (1-1/2 - 3)				270 (10.6)	415 (16.6)	345 (13.6)	130 (5.1)	90 (3.6)	68 (149.6)
GH8		80, 100 (3", 4")				350 (13.8)	590 (23.6)	470 (18.5)	174 (6.9)	120 (4.7)	162 (356.4)

< Dismounting Space >

Model	Dismounting Space
GH2	170mm
GH4	210mm
GH6	220mm
GH8	310mm

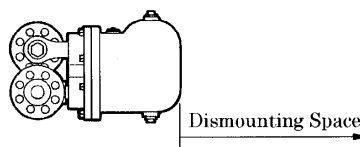

# 4 NAME OF THE COMPONENTS AND PARTS

## GH2

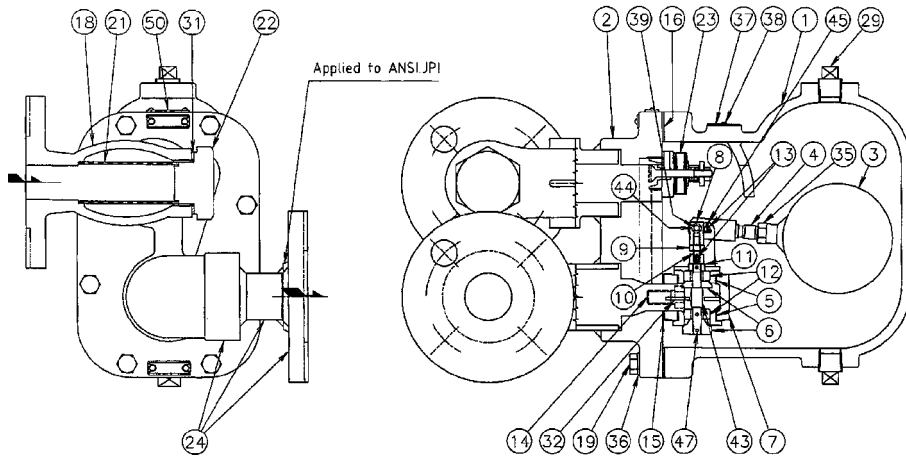

- |               |                    |                    |                |
|---------------|--------------------|--------------------|----------------|
| 1. Body       | 11. Nut            | 23. Air Vent       | 43. Shaft      |
| 2. Cover      | 12. Guide Wing     | 24. Connec. Flange | 44. Collar     |
| 3. Float      | 13. Pin            | 29. Plug           | 45. Split Pin  |
| 4. Lever      | 14. Bolt           | 31. Gasket         | 47. Spring Pin |
| 5. Valve Seat | 15. Gasket         | 32. Buffle Plate   | 50. Plate      |
| 6. Valve      | 16. Gasket         | 35. Nut            |                |
| 7. Holder     | 18. Connec. Flange | 36. Spring Washer  |                |
| 8. Lever Nut  | 19. Bolt           | 37. Name Plate     |                |
| 9. Nut        | 21. Screen         | 38. Rivet          |                |
| 10. Connector | 22. Plug           | 39. Pin            |                |

## GH4

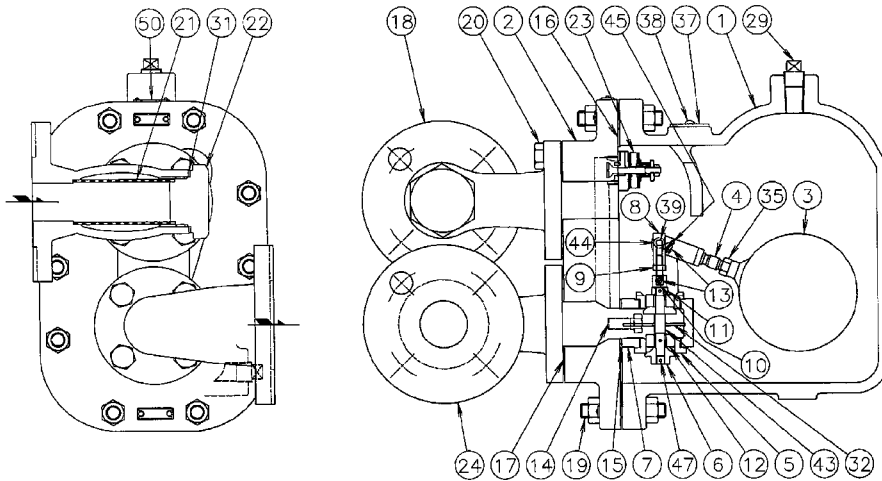

- |               |                    |                    |                |
|---------------|--------------------|--------------------|----------------|
| 1. Body       | 11. Nut            | 21. Screen         | 39. Pin        |
| 2. Cover      | 12. Guide Wing     | 22. Plug           | 43. Shaft      |
| 3. Float      | 13. Pin            | 23. Air Vent       | 44. Collar     |
| 4. Lever      | 14. Bolt           | 24. Connec. Flange | 45. Split Pin  |
| 5. Valve Seat | 15. Gasket         | 29. Plug           | 47. Spring Pin |
| 6. Valve      | 16. Gasket         | 31. Gasket         | 50. Plate      |
| 7. Holder     | 17. Gasket         | 32. Buffle Plate   |                |
| 8. Lever Nut  | 18. Connec. Flange | 35. Nut            |                |
| 9. Nut        | 19. Bolt, Nut      | 37. Name Plate     |                |
| 10. Connector | 20. Bolt           | 38. Rivet          |                |

## GH6

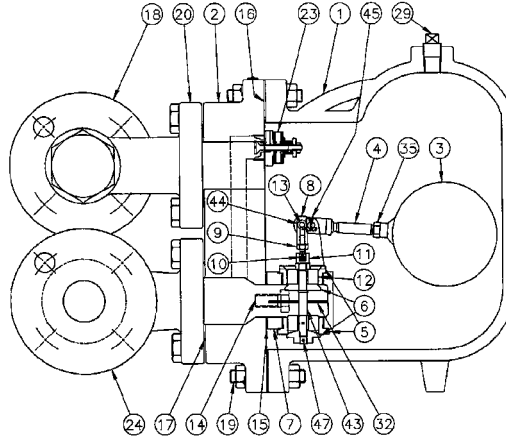
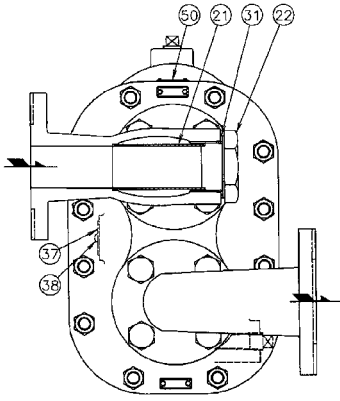

- |               |                    |                    |                |
|---------------|--------------------|--------------------|----------------|
| 1. Body       | 11. Nut            | 21. Screen         | 43. Shaft      |
| 2. Cover      | 12. Guide Wing     | 22. Plug           | 44. Collar     |
| 3. Float      | 13. Pin            | 23. Air Vent       | 45. Split Pin  |
| 4. Lever      | 14. Bolt           | 24. Connec. Flange | 47. Spring Pin |
| 5. Valve Seat | 15. Gasket         | 29. Plug           | 50. Plate      |
| 6. Valve      | 16. Gasket         | 31. Gasket         |                |
| 7. Holder     | 17. Gasket         | 32. Buffle Plate   |                |
| 8. Lever Nut  | 18. Connec. Flange | 35. Nut            |                |
| 9. Nut        | 19. Bolt, Nut      | 37. Name Plate     |                |
| 10. Connector | 20. Bolt           | 38. Rivet          |                |

## GH8

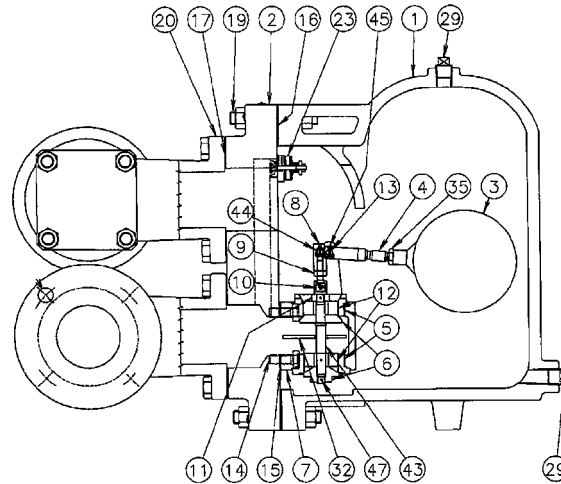
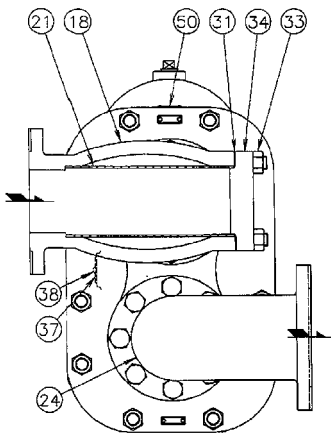

- |               |                    |                    |                |
|---------------|--------------------|--------------------|----------------|
| 1. Body       | 11. Nut            | 21. Screen         | 38. Rivet      |
| 2. Cover      | 12. Guide Wing     | 23. Air Vent       | 43. Shaft      |
| 3. Float      | 13. Pin            | 24. Connec. Flange | 44. Collar     |
| 4. Lever      | 14. Bolt           | 29. Plug           | 45. Split Pin  |
| 5. Valve Seat | 15. Gasket         | 31. Gasket         | 47. Spring Pin |
| 6. Valve      | 16. Gasket         | 32. Buffle Plate   | 50. Plate      |
| 7. Holder     | 17. Gasket         | 33. Bolt, Nut      |                |
| 8. Lever Nut  | 18. Connec. Flange | 34. Screen Cover   |                |
| 9. Nut        | 19. Bolt, Nut      | 35. Nut            |                |
| 10. Connector | 20. Bolt           | 37. Name Plate     |                |

## 5 INSTALLATION



### CAUTION

Before installing the product, open the isolation valves, and the bypass valve, if one exists, to blow off any debris or dust inside the pipeline.

- (1) Check the flow direction marked on the side of the body, and match with the arrow on the body.
- (2) This trap is for a horizontal installation. Be sure to create a slight downhill gradient so that the condensate will flow in and out smoothly.
- (3) The product should be installed for easy maintenance check.
- (4) Open the isolation valve on the primary line slowly and make sure the product works normally.
- (5) The outlet line should be piped from the steam trap as shown below.

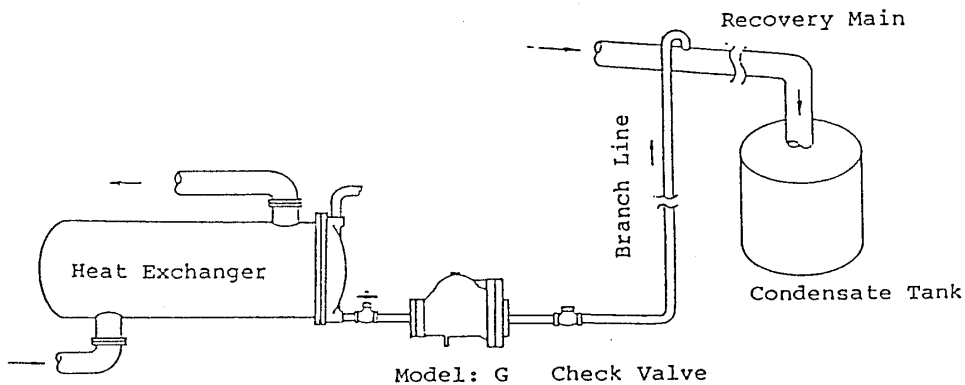

## 6 MAINTENANCE



When taking apart the trap from the line, close the both primary and secondary stop valve, and cool down the trap itself first to avoid the danger of steam and condensate blowout.

### WARNING

The performance of steam traps deteriorates over time due to wear, corrosion, or dirt accumulating around the valve seat. To keep steam systems and equipment working well, periodic maintenance of the steam traps is essential.

### Tools for testing steam traps

In order to test steam traps, ultrasonic testers, sound detectors, and thermometers have been used for years. These tools are relatively easy to use and are useful for making rough estimates of the level of deterioration in a defective trap. However, to determine deterioration levels and steam losses quantitatively, special tools are required for testing steam traps.

Dr. Trap and Dr. Trap Jr. are testing equipment that were developed specifically for diagnosing steam traps and analyzing survey results automatically. Use these tools to avoid tiresome jobs on sites and save working time.

### Working conditions of a steam trap

Steam trap failures can be classified as either 'Leaking' or 'Plugged'. The level of steam leaks is generally determined by the intensity of the ultrasonic vibration generated in the valve seat inside of a steam trap. The 'plugged' is diagnosed by measuring the surface temperature.

As the degree of plugging increases due to a buildup of dirt in the trap, it will finally become completely plugged.

Then the surface temperature will drop to around 40 degrees centigrade, or lower.

### Repairs

When a trap fails, it is necessary to clean the internal parts and replace damaged parts. Take the failed trap apart following the steps below.

- (1) Remove the trap from the piping. Take off the Bolt (19) (model GH4/GH6/GH8: Nut (19)) and dismantle the Body (1), all the inner parts are fixed to the Cover (2).
- (2) Take off the Bolt (14) with a wrench. The Valve Unit will be dismantled. The Float (3) can also be dismantled with a wrench.
- (3) Clean and inspect the Body (1) and the Valve Unit, if not defected assemble in the opposite way of disassembling.
- (4) If the Valve (6) and Valve Seat (5) are worn out or defected, replace the whole Valve Unit.
- (5) If the Float (3) is damaged, loosen the Nut (35) of the Lever (4) and turn the Float (3) by hand and replace it.
- (6) Take off the Plug (22) (model GH8: take off the Nut (33) and dismantle the Screen Cover (34)), take out Screen (21) and clean it.



When reassembling always replace the Gasket (15), (16), (31) to new ones.

Gaskets are fragile, so please handle with care.

**CAUTION** Bolt (14), (19), (33) should be tightened evenly.

\*The clamp torque of the screws will be as per the following chart.

**Torque table**

Model	No.	Parts	Size	Clamp Torque
GH2	14	Bolt	14 mm (0.55 inch)	30N·m (300 kgf·cm)
	19	Bolt	13 mm (0.51 inch)	50N·m (500 kgf·cm)
	22	Plug	46 mm (1.81 inch)	120 N·m (1,200 kgf·cm)
	23	Air Vent	32 mm (1.26 inch)	130 N·m (1,300 kgf·cm)
	35	Nut	13 mm (0.51 inch)	
GH4	14	Bolt	14 mm (0.55 inch)	40N·m (400 kgf·cm)
	19	Bolt, Nut	19 mm (0.75 inch)	60N·m (600 kgf·cm)
	20	Bolt	19 mm (0.75 inch)	80 N·m (800 kgf·cm)
	22	Plug	54 mm (2.13 inch)	150 N·m (1,500 kgf·cm)
	23	Air Vent	32 mm (1.26 inch)	130 N·m (1,300 kgf·cm)
	35	Nut	13 mm (0.51 inch)	
GH6	14	Bolt	19 mm (0.75 inch)	45N·m (450 kgf·cm)
	19	Bolt, Nut	19 mm (0.75 inch)	60N·m (600 kgf·cm)
	20	Bolt	24 mm (0.94 inch)	120 N·m (1,200 kgf·cm)
	22	Plug	60 mm (2.36 inch)	150 N·m (1,500 kgf·cm)
	23	Air Vent	32 mm (1.26 inch)	130 N·m (1,300 kgf·cm)
	35	Nut	13 mm (0.51 inch)	
GH8	14	Bolt	19 mm (0.75 inch)	80 N·m (800 kgf·cm)
	19	Bolt, Nut	24 mm (0.94 inch)	120 N·m (1,200 kgf·cm)
	20	Bolt	24 mm (0.94 inch)	120 N·m (1,200 kgf·cm)
	23	Air Vent	32 mm (1.26 inch)	130 N·m (1,300 kgf·cm)
	33	Bolt, Nut	24 mm (0.94 inch)	120 N·m (1,200 kgf·cm)
	35	Nut	17 mm (0.67 inch)	



**Assembly Drawing Of Model GH2**

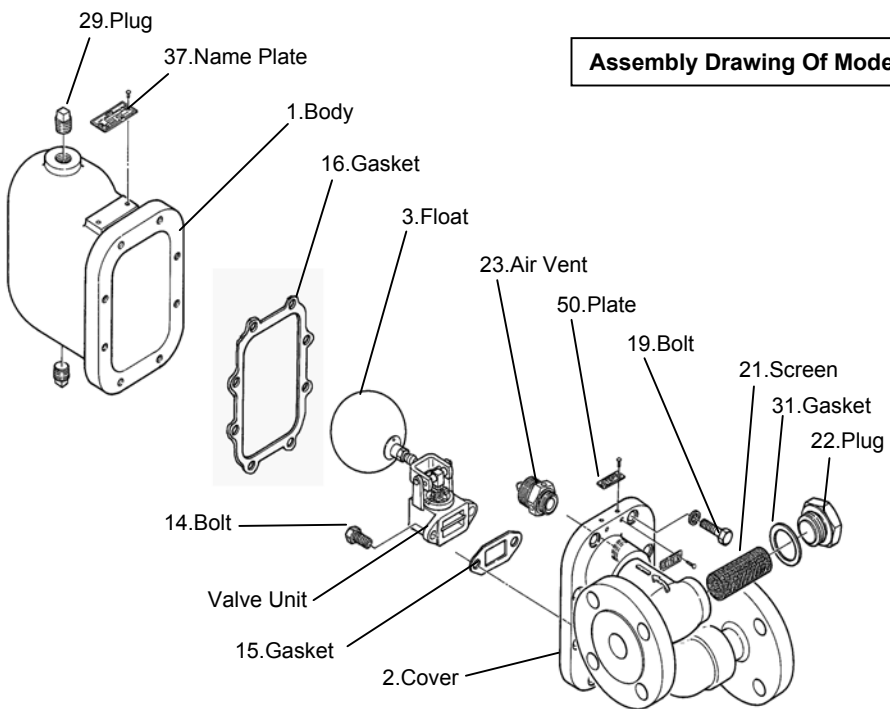

**Assembly Drawing Of Model GH4·GH6·GH8**

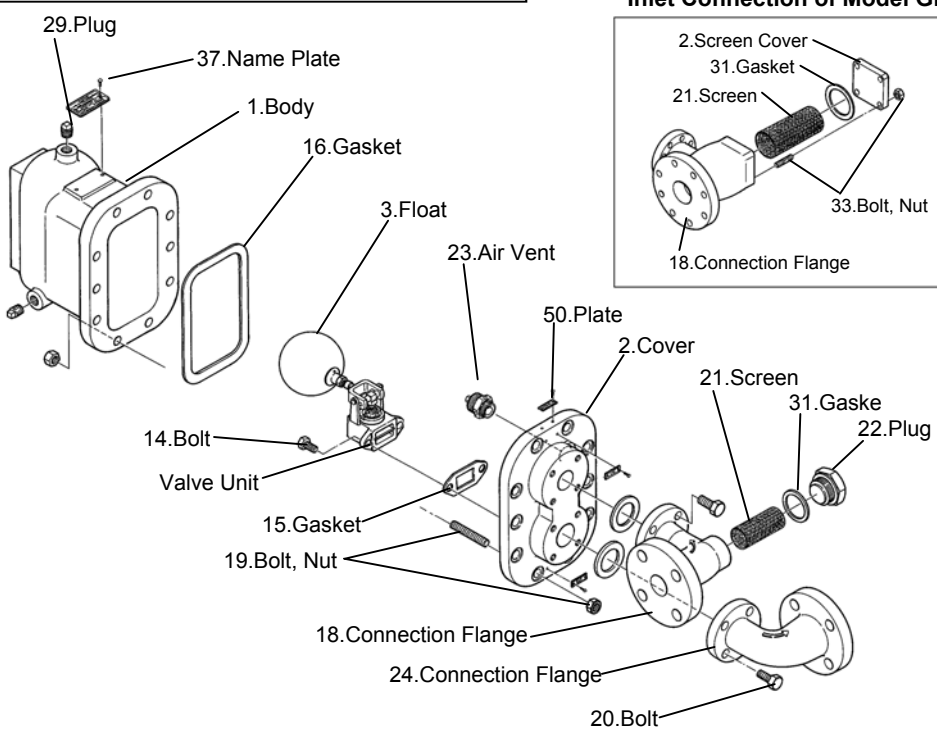

**Inlet Connection of Model GH8**

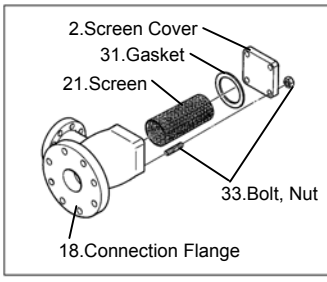

## 7 TROUBLESHOOTING

Problem	Possible Causes	Solution
Steam leaks or blows through	Stuck valve or dirt accumulated around Valve or Valve Seat.	Clean the Valve Unit.
	Stuck valve or dirt accumulated around Guide Wing or Valve Seat.	Clean the Valve Unit.
	Damage, wear or corrosion of Valve Unit.	Replace the Valve Unit.
	Bolt (14) is loose.	Tighten the Bolt.
	Air Vent is damaged.	Replace the Air Vent.
	Air Vent is loose.	Tighten the Air Vent.
	Gasket (15) is damaged.	Replace the Gasket.
	Gasket (54) is damaged.	Replace the Gasket.
	Improper installation.	Reinstall the product.
Steam leaks from the body	Bolt (19) or Nut (19) is loose.	Tighten the Bolt, Nut..
	Gasket (16) is damaged.	Replace the Gasket.
	Plug (22) is loose. (Model GH2 / GH4 / GH6)	Tighten the Plug.
	Bolt, Nut (33) is loose. (Model GH8)	Tighten the Nut.
	Gasket (31) is damaged.	Replace the Gasket.
	Bolt (20) is loose. (Model GH4 / GH6 / GH8)	Tighten the Bolt.
	Gasket (17) is damaged. (Model GH4 / GH6 / GH8)	Replace the Gasket.
	Plug (29) is loose.	Tighten the Plug.
Insufficient condensate discharged, or no condensate discharged	Dirt has built up on or around the Valve or Valve Seat.	Clean the Valve Unit.
	Float is damaged.	Replace the Float.
	Screen is clogged.	Clean the Screen.
	Air Vent is damaged.	Replace the Air Vent.
	Inlet valve is closed.	Open the Inlet Valve.
	Insufficient condensate capacity.	Replace the trap with a larger capacity.

\* See the torque table in Chapter 6.

## 8 LIMITED WARRANTY

Any trap that fails in normal operating conditions will be repaired free of charge.

### WARRANTY TERM

This warranty term shall be for the first 12 months of ownership, starting from the date of delivery to you.

### WHAT THIS WARRANTY DOES NOT COVER

- (1) Damage caused by careless use or ignoring the warnings and cautions given in this manual.
- (2) Damage caused by severe shock or an impact which would not be experienced in normal operation.
- (3) Damage caused by unauthorized modifications or repairs.
- (4) Damage caused by fire, natural disasters, or acts of God.
- (5) Damage caused by inappropriate handling or installation in a way that violates the specifications.
- (6) Damage caused by equipment, apparatus or devices that are not provided by MIYAWAKI.
- (7) Damage caused by chlorine, or other materials that are corrosive to metals or hasten deterioration.
- (8) Damage caused by a part such as a gasket that is severely deteriorated.
- (9) Damage caused by accumulated dirt or debris on or around the seat.

### WARRANTY SCOPE

In any event, the scope of the warranty is limited to compensation that does not exceed the purchase price of the product.