

G3N, G5 GH3N, GH5

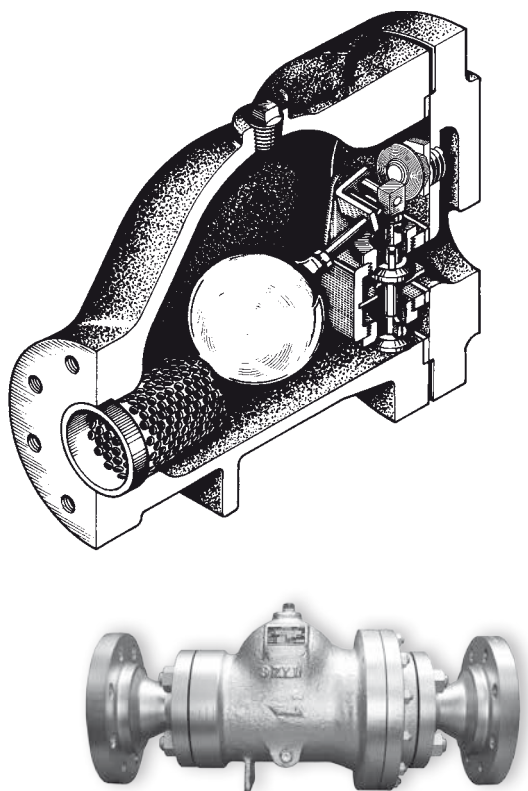

Capacity Chart

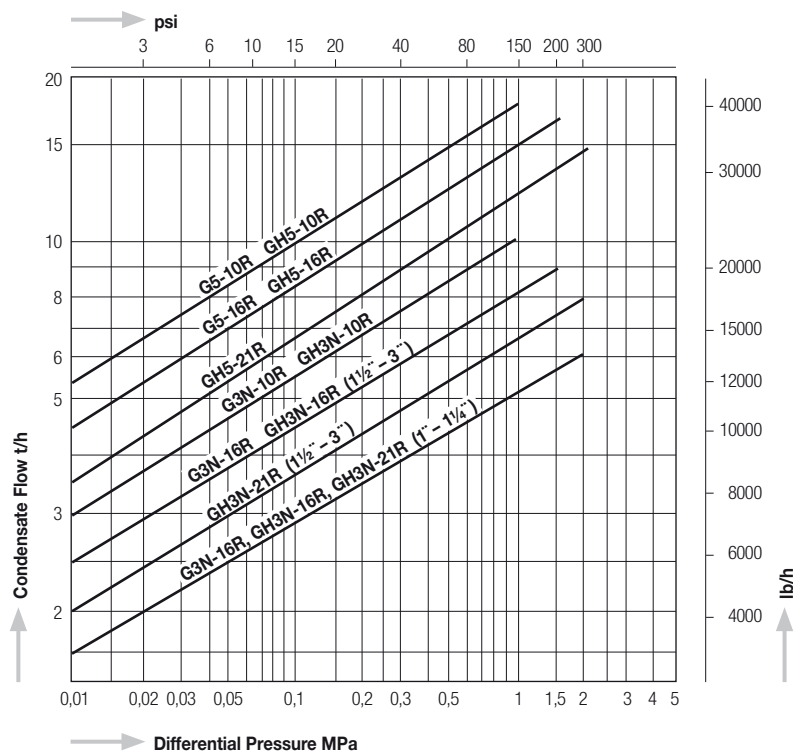

Dimensions G3N-R, G5-R, GH3N-R, GH5-R

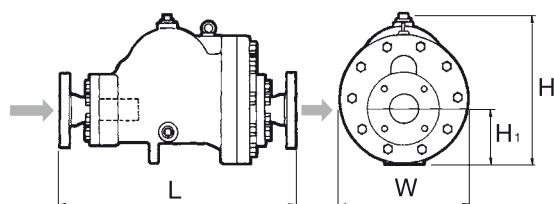

Model	Connections	Size (in)	Operating Pressure Range		Max. Operating Temperature		Dimensions (mm)				Dimensions (in)			Body Material	Weight				
			MPa	psig	°C	°F	L	H	H ₁	W	H	H ₁	W		kg	lb			
G3N - 10R 16R	Flanged	1½" - 3"	1,0	145	235	455	(*1)	140	95	198	5.5	3.7	7.8	Ductile Cast Iron FCD 450	28 - 31 (*2)	62 - 68 (*2)			
		1" - 3"	1,6	230				(*1)	205	110	270	8.1	4.3		10.6	52 - 69 (*2)	114 - 152 (*2)		
G5 - 10R 16R		2" - 4"	1,0	145			400		752	(*1)	139	106	212		5.5	4.2	8.3	Cast Steel SCPH2	38 - 50 (*2)
		2" - 4"	1,6	230				(*1)			200	115	270		7.9	4.5	10.6		63 - 80 (*2)
GH3N - 10R 16R		1½" - 3"	1,0	145	(*1)	(*1)				200	115	270	7.9	4.5	10.6	63 - 80 (*2)	139 - 176 (*2)		
		1" - 3"	2,1	305															
GH5 - 10R 16R		2" - 4"	1,0	145	(*1)	(*1)		200		115	270	7.9	4.5	10.6	63 - 80 (*2)	139 - 176 (*2)			
		2" - 4"	1,6	230															
GH5 - 16R 21R		2" - 4"	2,1	305	(*1)	(*1)	200	115	270	7.9	4.5	10.6	63 - 80 (*2)	139 - 176 (*2)					
		2" - 4"	2,1	305															

All steam traps are available with flanges according to ASME, DIN (EN) and JIS standards.

(*1) Depending on size and flange standard the face-to-face dimensions differ. Please, look at our technical drawings.

(*2) Depending on size and flange standard the weight of the traps differs. Please, look at our technical drawings.