

## Series 05 Declutchable Gear Operator Installation, Maintenance and Operations Instructions

**WARNING**

indicates a potentially hazardous situation which, if not avoided, **could** result in death or serious injury.

**CAUTION**

indicates a potentially hazardous situation which, if not avoided, may result in minor or moderate injury.

**NOTICE**

used without the safety alert symbol indicates a potential situation which, if not avoided, may result in an undesirable result or state, including property damage.

### I. General

**WARNING**

Failure to install and operate the Series 05 Gear Operator as defined in this manual can cause severe damage to equipment.

- A. The Bray Series 05 Declutchable Manual Override Gear Operator is typically mounted between a valve and a Bray Series 92 Pneumatic Direct Acting Actuator or Series 93 Pneumatic Spring Return Actuator. It is used to permit manual operation of the valve in case of a loss of operating air pressure. Special caution is required when using the Series 05 with a Series 93 spring-return actuator. Refer to Section III, Paragraph B of these instructions.
- B. If you are ordering an S05 Gear Operator to place in an existing assembly, confirm that sufficient space is available in the pipeway as the override gear adds considerable height to the valve and actuator assembly.

Refer to [www.braycontrols.com](http://www.braycontrols.com) for Series 05 general dimensions.

**CAUTION**

- C. Disconnect the air supply to the S92/93 actuator when operating the S05 gear operator. Conversely, when the S92/93 actuator is being operated, disengage the S05. Failure to do so will prevent the assembly from operating properly and may damage some equipment.
- D. The clutch lever is attached to an eccentrically-bored bearing which houses the input shaft. The rotation of the clutch handle is restricted to 180°.
- E. When the handle is at the far left position, the gear is disengaged allowing powered operation of the valve. Turning the handle 180° clockwise engages the worm on the input shaft with the drive sleeve segment gear allowing manual operation of the valve.
- F. Series 05 gear operators are internally lubricated at the factory for the life of the product and are sealed from the environment. No routine maintenance is required except an occasional check to assure that external corrosion or damage does not prevent operation of the unit.

## II. Installation Procedures

A. **Before you begin**, several checks must be carried out and decisions made regarding the orientation of the actuator and S05 Gear Operator.

1. The S05 can be oriented with the handwheel input shaft either perpendicular or parallel to the pipeline for standard clockwise-to-close operation without any special modification. The orientation of the S92/93 actuator, either perpendicular or parallel to the pipeline, does not depend on the orientation of the S05 manual override gear. Refer to Fig. 1 for typical installation orientations.
2. Check to make sure that the valve, the S05 Gear Operator and the S92/93 actuator are all at the same operating position, open or closed. Failure to do so will prevent the assembly from operating properly and may damage some equipment. When checking the S05, view it from above. The output drive should rotate clockwise while the valve is closing.
3. If the actuator to be mounted is an S93 spring-return actuator, it is recommended, but not necessary, to remove the spring cartridges before beginning. Remember the configuration of the spring cartridges and replace them before air is supplied to the actuator. Replace the springs in the S93 when the pistons are in the fully closed position. That is, the actuator pinion is in the full clockwise position.

B. **Installation may now begin.** The following are the minimum essential steps required for a typical installation.

1. Carefully examine the parts in the kit to make sure where each is used. Refer to exploded view drawing Fig. 1 for a typical assembly. The 24:1 unit requires an adapter spool between the S05 and the actuator mounting flange on the valve. Some larger gearboxes have drilled and tapped holes in the base to fit directly to the valve. Still others require an adapter/spacer plate between the valve and the S05.
2. Remove the four housing bolts or studs from the S05.
3. There are two stem adapters, one fits over the valve stem and halfway into the S05 drive sleeve; the other connects the remaining S05 drive sleeve space with the S92/93. Square up the S05 with the valve.

4. Place the S92/93 stem adapter into the S05 drive. If a stem collar was supplied, slip it over the double-D and place the actuator over it. Thread the nuts and lock washers on the studs and tighten.

## III. Operation

- A. It is recommended to cycle the valve fully with the S05 before supplying air to the S92/93 to ensure that all the connections are made correctly. A temporary hissing sound from the ports is not an indication of a leak in the S92/93; it is simply displaced air exiting the actuator. If the pneumatic actuator is an S93, it will become increasingly difficult to rotate the valve open (fail closed) or close (fail open) with the S05 because the pistons are compressing the spring cartridges; for the same reasons, it will be difficult to disengage the clutch. This is not an indication that there is a malfunction in the assembly.
- B. It is important not to disengage the S05 if the S93 is applying torque via compressed springs, otherwise damage may occur to the unit or to the driving couplings between the S93 and the valve.



### CAUTION

C. **Before supplying air to the S92/93, disengage the clutch.** The drive gear in the S05 always rotates with the valve regardless of whether the clutch is engaged. If the clutch is engaged, the drive gear will push against the worm gear and damage may occur to the internal components.

- D. It is important to adjust the travel stops on the S92/93 to the fully opened position. In the event that operating air pressure is cut and the valve needs to be opened, use the S05 to open it fully against the S92/93 travel stops. Failure to do so can run the drive gear against the worm gear when air pressure is resupplied. Damage may occur to the unit or to the internal parts.

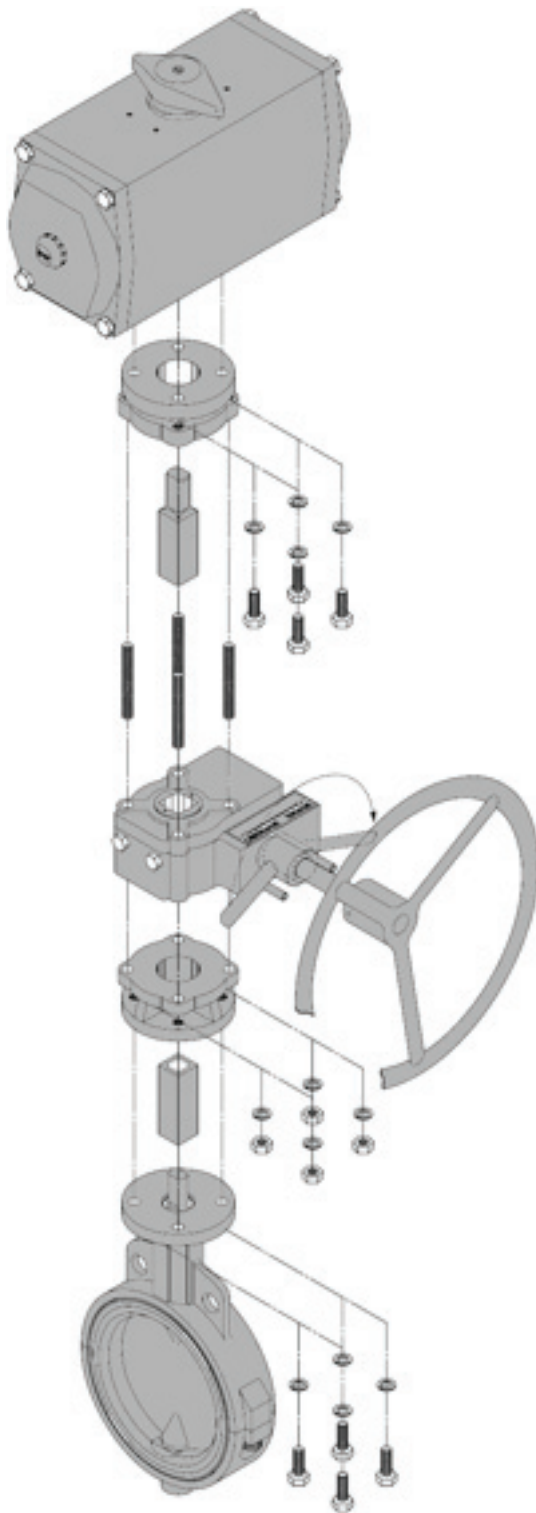

**Figure 1.** General Series 05 assembly.

**For dimensional data please visit**

<http://www.braycontrols.com/information/productline/111009/display/techInfo/show/Drawings>

---

All information herein is proprietary and confidential and may not be copied or reproduced without the expressed written consent of BRAY INTERNATIONAL, Inc.

The technical data herein is for general information only. Product suitability should be based solely upon customer's detailed knowledge and experience with their application.