

Bray CONTROLS

OPERATION AND MAINTENANCE MANUAL

SERIES 6P

Pneumatic Positioner

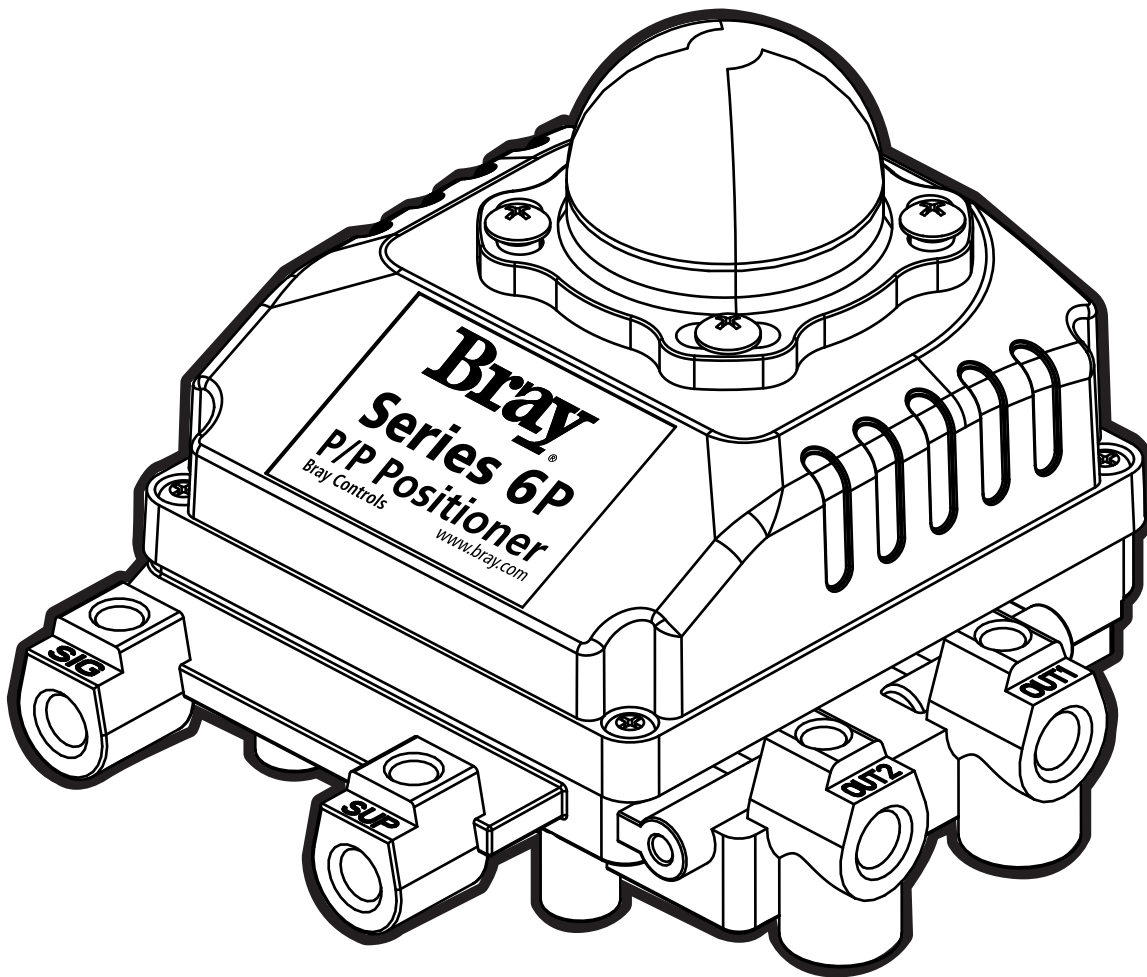

SAFETY INSTRUCTIONS - DEFINITION OF TERMS

**READ AND FOLLOW THESE INSTRUCTIONS
SAVE THESE INSTRUCTIONS**



WARNING

indicates a potentially hazardous situation which, if not avoided, **could** result in death or serious injury.



CAUTION

indicates a potentially hazardous situation which, if not avoided, may result in minor or moderate injury.

NOTICE

used without the safety alert symbol indicates a potential situation which, if not avoided, may result in an undesirable result or state, including property damage.



CAUTION

Beware of moving parts when positioner is operated!



CAUTION

Do not exceed the positioner operating limitations!

Exceeding the limitations marked on the positioner may cause damage to the positioner, actuator and valve.



CAUTION

Do not dismantle a pressurized positioner!

Dismantling a pressurized positioner will result in uncontrolled pressure release. Always isolate the relevant part of the pipeline. Release the pressure from the positioner and the piping.

Bray CONTROLS

SERIES 6P *Pneumatic Positioner*

TABLE OF CONTENTS

	PAGE
INTRODUCTION	4
PRODUCT DESCRIPTION	4
MANUFACTURER WARRANTY	4
OPERATION LOGIC	5
LABEL DESCRIPTION	6
SPECIFICATIONS	6
PARTS AND ASSEMBLY	7
DIMENSIONS	8
INSTALLATION	8
BRACKET INFORMATION	9
PIPING CONNECTION	10
ADJUSTMENT & CALIBRATION	11
TROUBLE SHOOTING	12

Introduction

Every Series 6P is fully inspected after production to offer the highest quality products. However, we strongly recommend users read this manual carefully to ensure the product is utilized to its fullest potential.

- This manual should be given to the end-user.
- This manual may be changed or revised without any prior notice. The most current version of this O&M is available at www.bray.com.

Product Description

Main Features and Functions

- The product has been designed to operate normally in a typical industrial environment.
- The durability has been proven after testing for two million cycles under typical operating conditions.
- Response time is very quick and accurate.
- Can be easily switched to a 2 way split range by changing the Span Spring
- High energy efficiency due to its low air-consumption.
- Simple Zero & Span adjustment procedures.
- Position Feedback and switch modules are available.
- Convert Double Acting to Single Acting simply by putting a pipe plug in OUT 2.

Manufacturer Warranty

Warranty - Bray provides the following warranty regarding products manufactured by it.

THE WARRANTY STATED HEREIN IS EXPRESSLY IN LIEU OF ALL OTHER WARRANTIES AND REPRESENTATIONS, EXPRESSED OR IMPLIED, OR STATUTORY, INCLUDING, WITHOUT LIMITATION, THE IMPLIED WARRANTY OF MERCHANTABILITY OR THE IMPLIED WARRANTY OF FITNESS FOR A PARTICULAR PURPOSE.

Bray warrants its products to be free from defects in materials and workmanship when these products are used for the purposes for which they were designed and manufactured. Bray does not warrant its products against chemical or stress corrosion or against any other failure other than from defects in materials or workmanship. The warranty period is for twelve (12) months from installation date or eighteen (18) months from shipment date, whichever date comes first. Any claim regarding this warranty must be in writing and received by Bray before the last effective date of the warranty period. Upon Bray's receipt of a warranty claim, Bray reserves the right to inspect the product(s) in question at either the field location or at Bray's Manufacturing Plant. If, after inspection of the product(s) in question, Bray determines that the purchaser's claim is covered by this warranty, Bray's sole liability and the purchaser's sole remedy under this warranty is limited to the refunding of the purchase price or repair or replacement thereof at Bray's option. Bray will not be liable for any costs of repairs, labor, material, or other expenses that are not specifically authorized in writing by Bray, and in no event shall Bray be liable for any direct or consequential damages arising out of any defect or from any cause whatsoever. If any Bray product is modified or altered at any location other than Bray's Houston Manufacturing Plant without the express written authorization of Bray, then this warranty is null and void. Any products sold by Bray but manufactured by companies other than Bray are not covered by this warranty. The warranty for such products shall be subject only to the warranty relief, if any, provided by the suppliers and/or manufacturers of such products.

Operation Logic

- When signal input pressure increases, the bellows (11) pushes the flapper (13), the gap between the nozzle (5) and the flapper (13) increases, which causes pressure in the upper spool chamber (4) to exhaust. This causes the spool (1) to shift right.
- As the spool (1) moves right, it pushes the poppet (2) off its seat (3), and air pressure is supplied to the center actuator chamber (9).
- At the same time, the spool (1) causes the left poppet (14) to seat and vent the outer chambers (10).
- As the actuator's inner pressure increases, the actuator stem (8) rotates.
- When the signal input pressure decreases, the spool (1) moves to the left reversing the action, lifting the left poppet (14) and supplying pressure to the outer actuator chambers (10) and venting the inner actuator chamber (9).

Bray Series 6P

1. Spool
2. Right Poppet
3. Seat
4. Spool Chamber
5. Nozzle
6. Span Adjustment
7. Cam
8. Actuator Stem
9. Inner Actuator Chamber
10. Outer Actuator Chamber
11. Bellows
12. Zero Adjustment
13. Flapper
14. Left Poppet
15. Feedback Springs

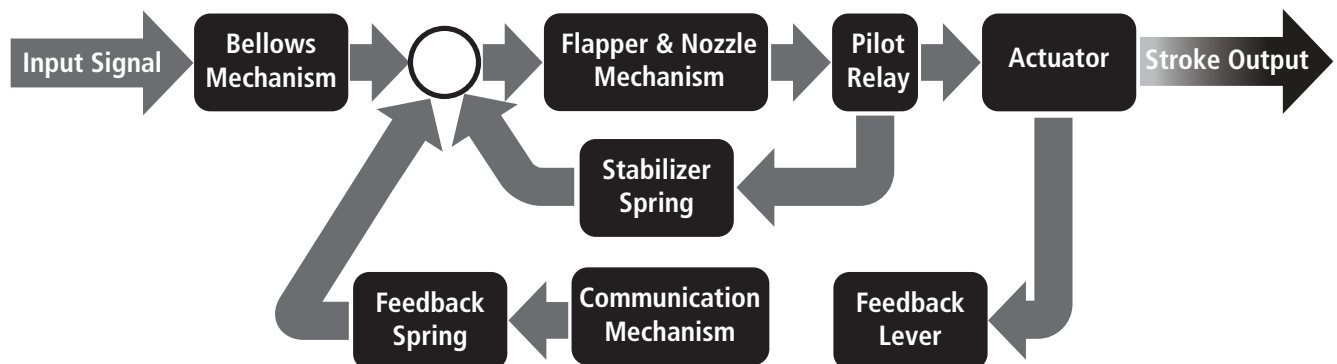
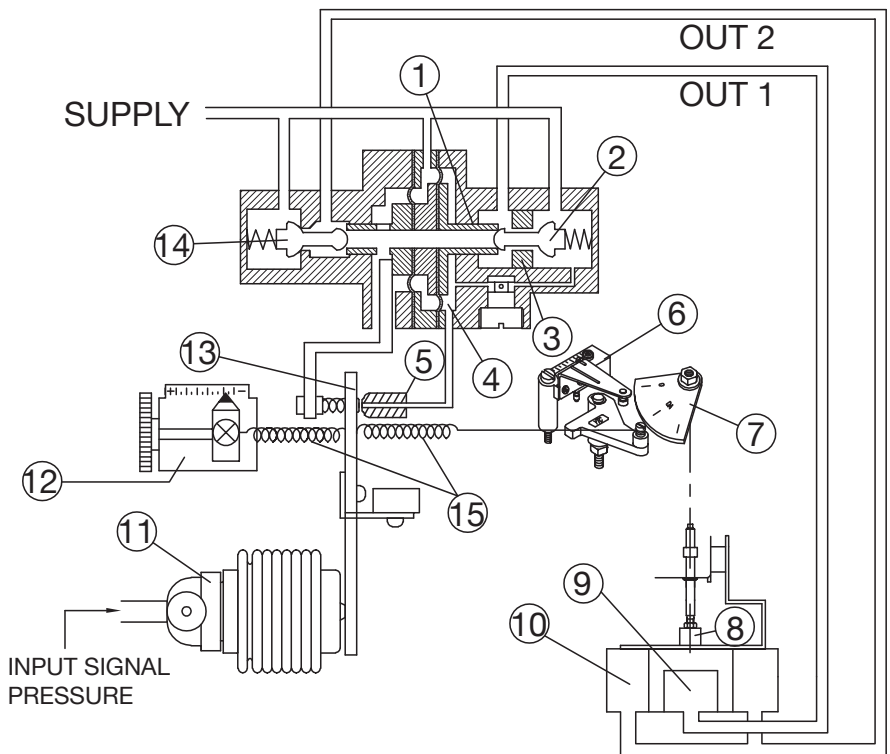





Figure 1

Label Description

MODEL	: 6P-0000-11600-533	  II 2 Gc IIc Korea
AIR CONNECTION	: NPT 1/4	
SUPPLY PRESSURE	: 20-100psi (1.4-7bar)	
INPUT SIGNAL	: 3-15psi (0.2-1bar)	
SERIAL NUMBER	: XXXXXXXXXXXXX	
		



NOTICE

All Series 6P positioners are supplied as Double Acting. For Single Acting operation, OUT 2 should be plugged with a 1/4" NPT plug.

Specifications

Category	Double Acting / Single Acting Pneumatic
Input Signal	3-15 psig (0.2 - 1.0 barg)
Supply Pressure	20-100 psig (1.4 - 7.0 barg)
Stroke	0 to 90°
Air Connection	1/4" NPTF
Gauge Connection	1/8" NPTF
Protection	IP66
Cam	Linear & Optional Reverse Acting
Ambient Temperature Ranges	Std. = -4°F to +158°F (-20°C to +70°C) High = -4°F to +248°F (-20°C to +120°C) Low = -40°F to +158°F (-40°C to +70°C)
Linearity	±2.0% Full Scale (F.S.)
Hysteresis	±1.0% Full Scale (F.S.)
Sensitivity	±0.5% Full Scale (F.S.)
Repeatability	±0.5% Full Scale (F.S.)
Air Consumption	.1 Acfm (1.4 LPM) @ 20 psia (1.4 barA) .39 Acfm (11 LPM) @ 60 psia (4 barA)
Flow Capacity	2.8 Acfm (80 LPM) @ 20 psia (1.4 barA) 7.1 Acfm (200 LPM) @ 60 psia (4 barA)
Housing Material	Die-cast Aluminum, Powder-coated
Weight	3.7 lbs (1.7 kg)

Parts and Assembly - Figure 2

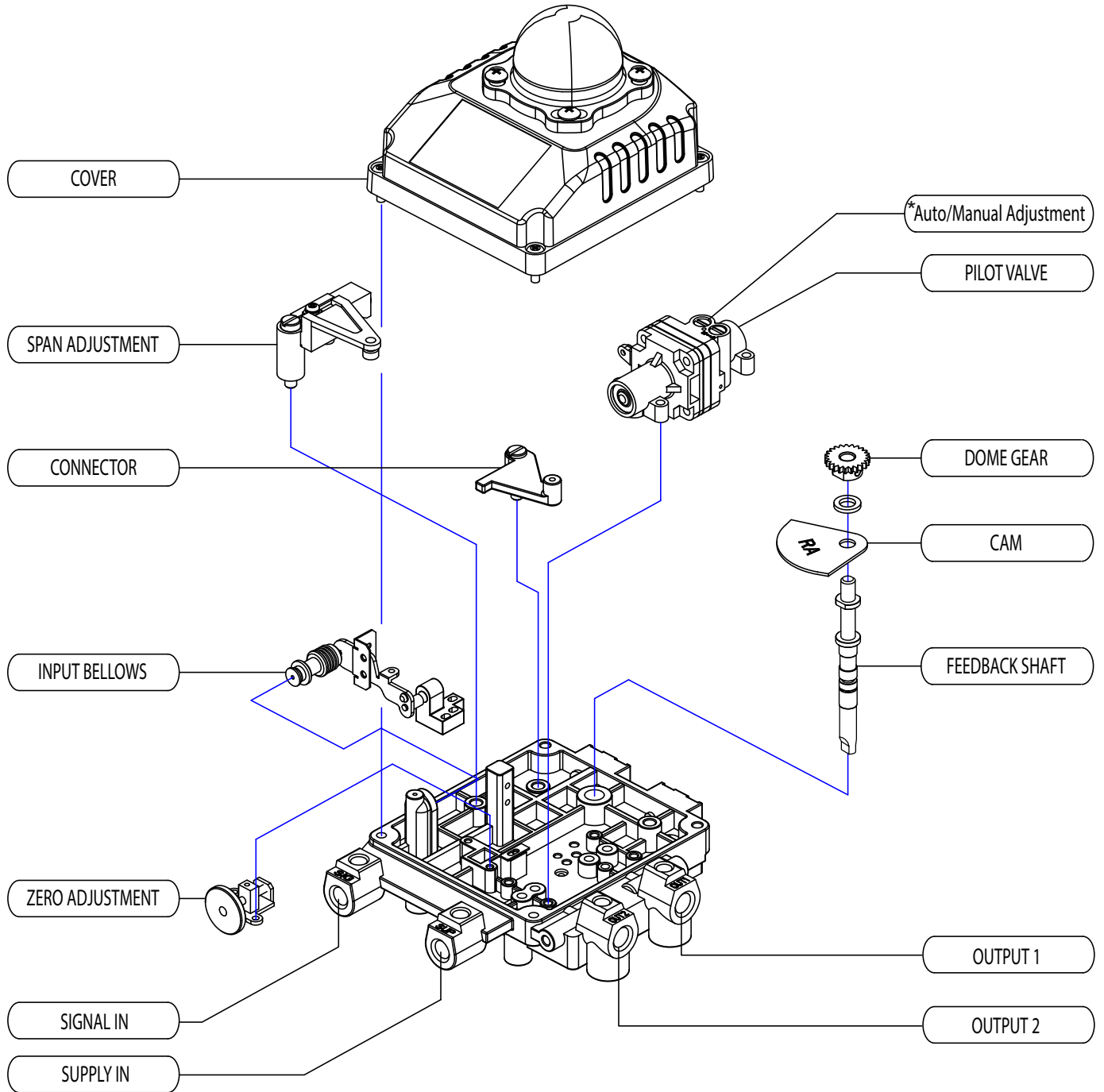

*Auto / Manual Adjustment is Factory set, and should not be adjusted.

Dimensions in Inches (mm)

Figure 3

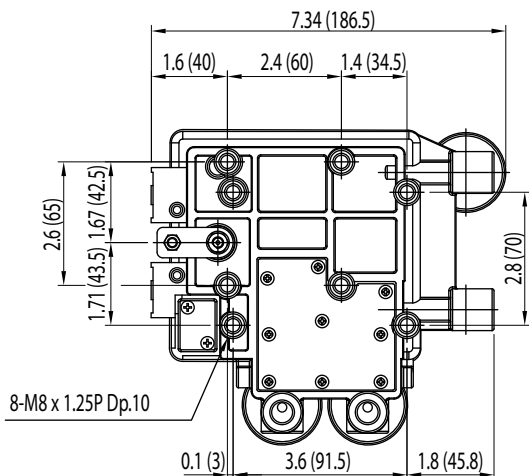
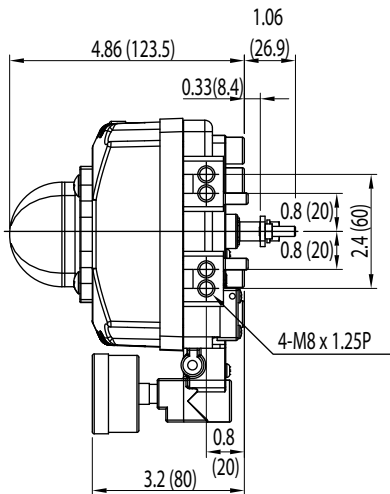
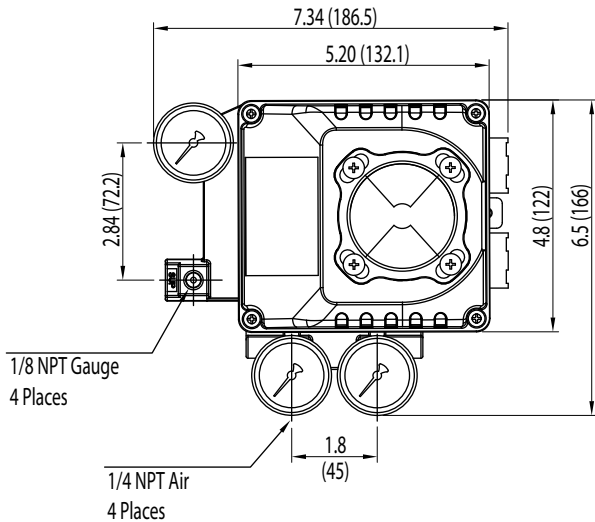

Installation



CAUTION

When installing a positioner, please read and follow all safety instructions:

- Series 6P should be used for quarter-turn valves and actuators only.
- All input and supply pressure to valve, actuator, and other related devices must be turned off.
- Use a bypass valve or other equipment to avoid entire system shut down.
- Make sure there is no remaining pressure in the actuator.

Tools for Installation

1. Allen wrenches
2. Phillips and Flathead Screwdrivers
3. Wrench for hex-head bolts

Before installation, be sure to check for the following installation components.

1. 1 Main Body
2. 1 bracket set (3 pcs)
3. 8 pcs of hex head bolt M8 x 1.25P w/ washers
4. 12 pcs of M7 allen screws, lock washers & nuts
5. ¼” NPT plug

Note: All Series 6P positioners are supplied as Double Acting. For Single Acting (Spring Return) operation OUT 2 should be plugged with a ¼” NPT plug (See Figure 2 - pg. 7)

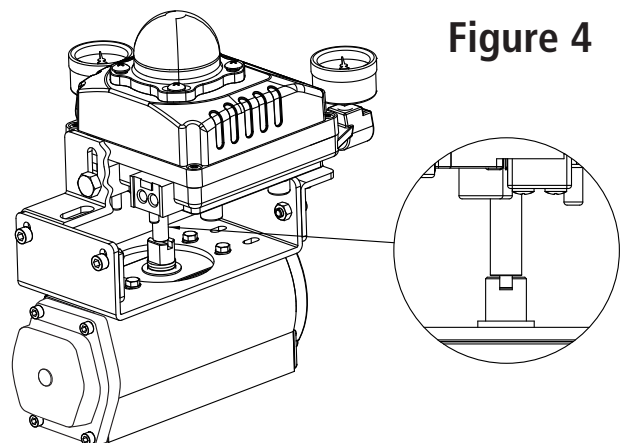

Figure 4

Bracket Information

The Series 6P is supplied with a standard adjustable bracket for NAMUR mounting.

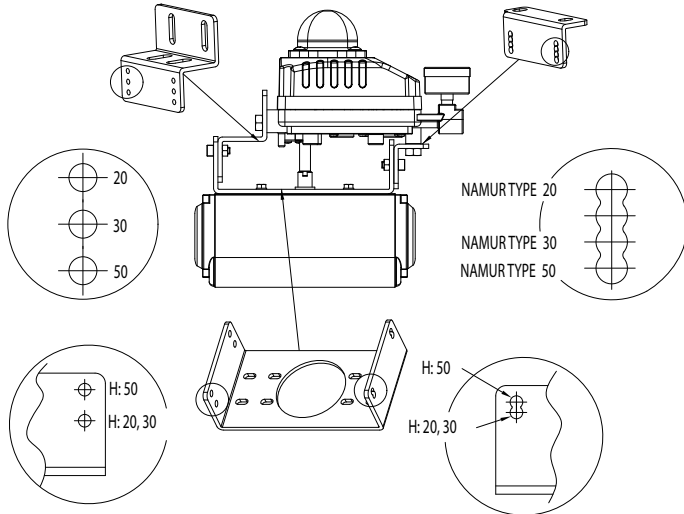

Figure 5

NOTICE

Care must be taken when assembling the two top brackets to the bottom brackets. Please refer to **Figure 5** for proper placement. Failure to do so will cause the positioner to be misaligned to the actuator shaft causing binding and poor performance.

1. Standard actuator stem height (**H**) is .79” (20mm), 1.18” (30mm), or 1.96” (50mm). After checking “H” (**Figure 6**), assemble with the bracket as shown in **Figure 5**.

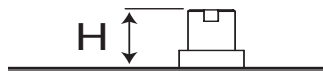

Figure 6

2. Set rotation position of the actuator stem at the zero point. For a Spring Return Actuator, Zero point is the position at which the actuator rests with no supply pressure. If a Double Acting actuator is used, check actuator stem’s rotation direction (clockwise or counter-clockwise) by supplying pressure.

3. Attach the Series 6P to the bracket as shown in **Figure 8**. This sets the alignment of the main shaft and the center of the actuator stem.

NOTICE

Misalignment of the main shaft and the actuator stem lowers the Series 6P’s sensitivity, because too much side force will be imposed on the feedback shaft.

4. Tighten the Series 6P base and the bracket hex-headed bolts to the actuator after checking the position using the supplied Hex Head Bolts, Spring Washers, and Lock Washers. M5 or #10-32 bracket to actuator mounting screws are supplied depending on specified actuator drilling

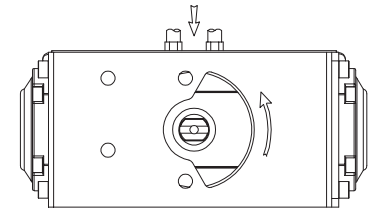

Counter-Clockwise

Figure 7

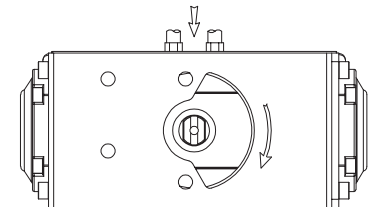

Clockwise

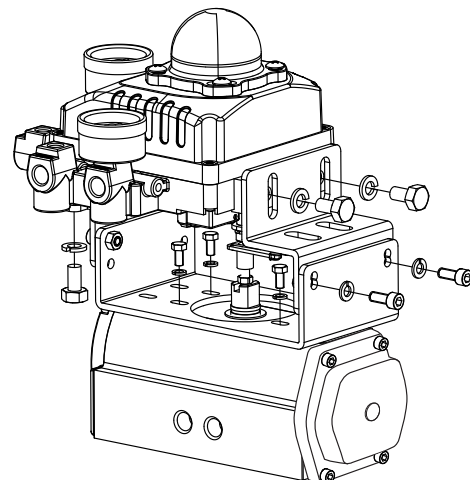

Figure 8

5. Piping Connections

NOTICE

To avoid introducing moisture or dust, both supply and signal air should be clean, dry, and filtered instrument air.

Supply Pressure Condition

1. Dry air with dew point of at least 50°F (10°C) lower than ambient temperature.
2. Avoid dirty or oily air. Filtered air is recommended in compliance with ANSI/ISA-573 1975 (R1981) instrument grade.
3. Do not use beyond the range of 20-100 psig (1.4 - 7.0 barg) supply air.
4. Set air filter regulator's supply pressure 10% higher than the actuator's spring range pressure.

Pipe Condition

1. Make sure the inside of tubing is clean and clear.
2. Do not use tubing that has been pinched or has holes.
3. To maintain proper flow rate, use a tube size that is at least ¼" (6mm) inner diameter.
4. Do not use extremely long tubing systems. It may affect the flow rate due to excessive pressure drop.

Piping connection with actuator

Series 93 Spring Return Actuator

When mounting on the Bray S93 Spring Return Actuator, OUT 1 should be connected to port A (left port when facing the ports) and OUT 2 should be plugged. This generates increasing pressure, forcing the pistons away from each other, causing a counter-clockwise rotation compressing the springs with increasing signal to the positioner. When mounting to other manufacturers rack and pinion actuators or other actuator types, check actuator documentation to determine proper connection.

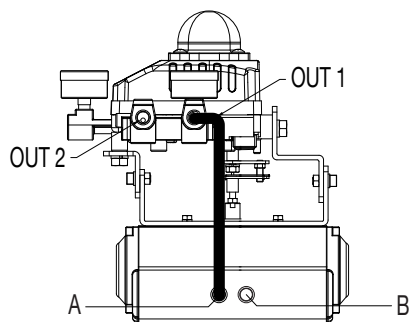

Figure 9 - Single Acting

Series 92 Double Acting Actuator

When mounting on the Bray S92 Double Acting Return Actuator, OUT 1 should be connected to port A (left port when facing the ports). OUT 2 should be connected to port B (right port when facing the ports). These connections will cause the pistons to move away from each other causing a counter-clockwise rotation with increasing signal to the positioner, and clockwise on decreasing signal. When mounting to other manufacturers rack and pinion actuators or other actuator types, check actuator documentation to determine proper connection.

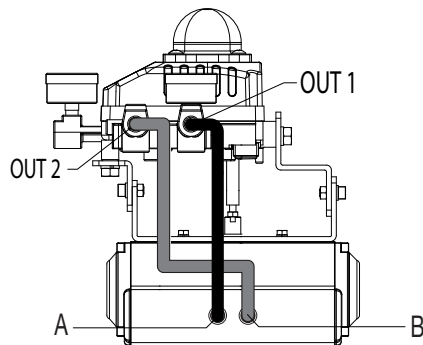

Figure 10 - Double Acting

Adjustment – Cam

1. If the valve actuator rotates counter-clockwise to open the valve on increasing air signal, the face of the cam must show “RA (CCW)” (Factory Default). If used on a valve-actuator which rotates clockwise to open the face of the cam must show “DA (CW)” on the face.
2. With the valve in the closed position, loosen the cam locking allen key and adjust the cam so the reference line on the cam points to the center of the bearing.

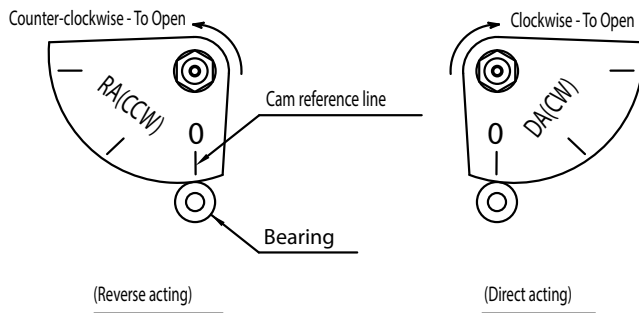

Figure 11

Adjustment – Zero Point

1. Set the signal to 3 psi. Rotate or turn the Zero Adjustment wheel clockwise or counter-clockwise so the pressure at OUT 1 port just begins to change.

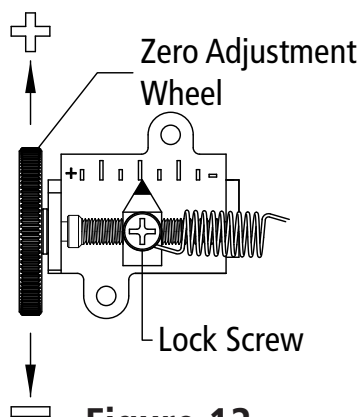

Figure 12

Adjustment – Span

1. After setting the Zero Point, increase the signal pressure to 15 psi. Loosen the locking screw slightly, and rotate or turn the Span Adjustment Screw clockwise or counter-clockwise until the actuator achieves its 90° or full open position.
2. Changing the Span Adjustment affects the Zero Point setting. Decrease signal to 3 psi and re-check the Zero Point and adjust as needed.
3. Re-check the Span Adjustment Screw by repeating step 1. Steps 1 & 2 may need to be repeated several times to optimally calibrate the positioner. Once the Span and Zero Point are set, tighten the Zero and Span Locking Screws shown below.

NOTICE

The Series 6P may be 2 way split range by changing the Span Spring. Consult factory for additional parts required.

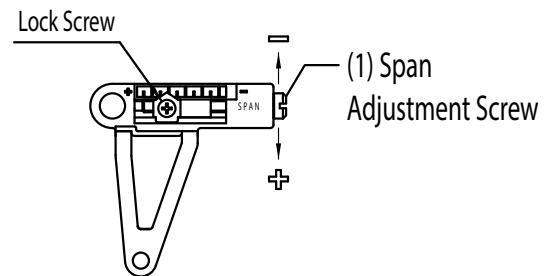

Figure 13



CAUTION

Be cautious of moving positioner, actuator, and valve parts while operating.

Adjustment – Poppet Seat Balance Pressure A/M Adjustment

NOTICE

The Poppet Seat Adjuster is factory set and sealed before the positioner is shipped. Do not adjust Auto / Manual default setting (Automatic) as shown.

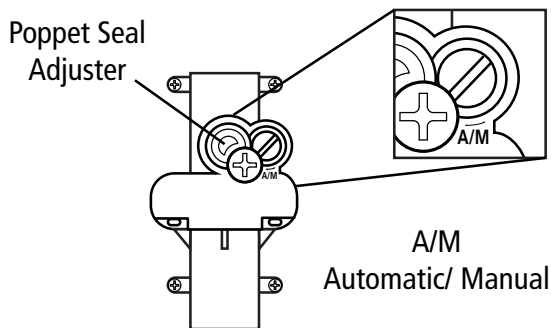

Figure 14

Troubleshooting

Positioner does not respond to the input signal

1. Check the supply pressure to the actuator. The supply must be at least 40 psi / 2.7 Bar / 0.27 MPa
2. Check if input signal is properly supplied to the positioner. The signal range should be 3-15 psi.
3. Check if the positioner's nozzle (5) has been blocked. If the nozzle has been blocked by any substances, please contact your local Bray distributor for a replacement.
4. Check if feedback shaft has been adjusted properly and engaged to actuator pinion.

The pressure of OUT 1 reaches exhausting pressure level and does not come back down

1. Check Auto/Manual (A/M) switch. For proper operation it must be in the "A" position.
2. Check for a gap or damage between the nozzle (5) and the flapper (13). If damaged, please contact your local Bray distributor.

Hunting occurs

- Check if feedback springs (15) have been displaced.
- Hunting may occur when the positioner is attached to a very small capacity actuator (ex: Bray Series 92/93 size 48). In such case, install an output orifice for OUT 1 and OUT 2 per the following steps.

1. Remove Pilot Valve Assembly (Figure 2).
2. Remove the O-ring from OUT 1 and OUT 2 port, install orifice in and reinstall the O-ring to OUT 1 and OUT 2 again. When mounting the output orifice, pay attention not to let dust or debris enter the orifice (Figure 16).
3. If hunting does not stop after installing the output orifice, please contact your local

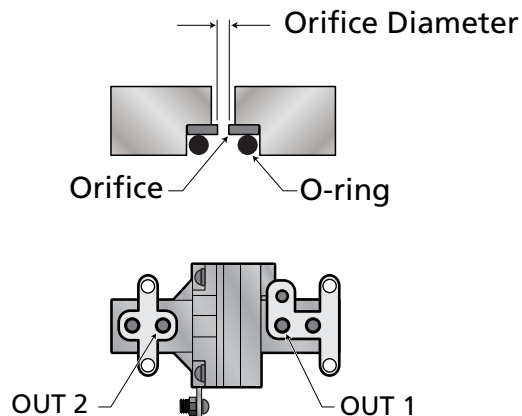

Figure 15

Bray distributor.

Actuator only operates Open or Closed

1. Check tubing connection
2. Check cam direction

Linearity is too low

1. Check if Zero and Span has been properly adjusted.
2. Check if supply air pressure level is stable from the regulator. If the level is unstable, replace the regulator.