

SERIES 70

ELECTRIC ACTUATOR

Installation, Operation and Maintenance Manual

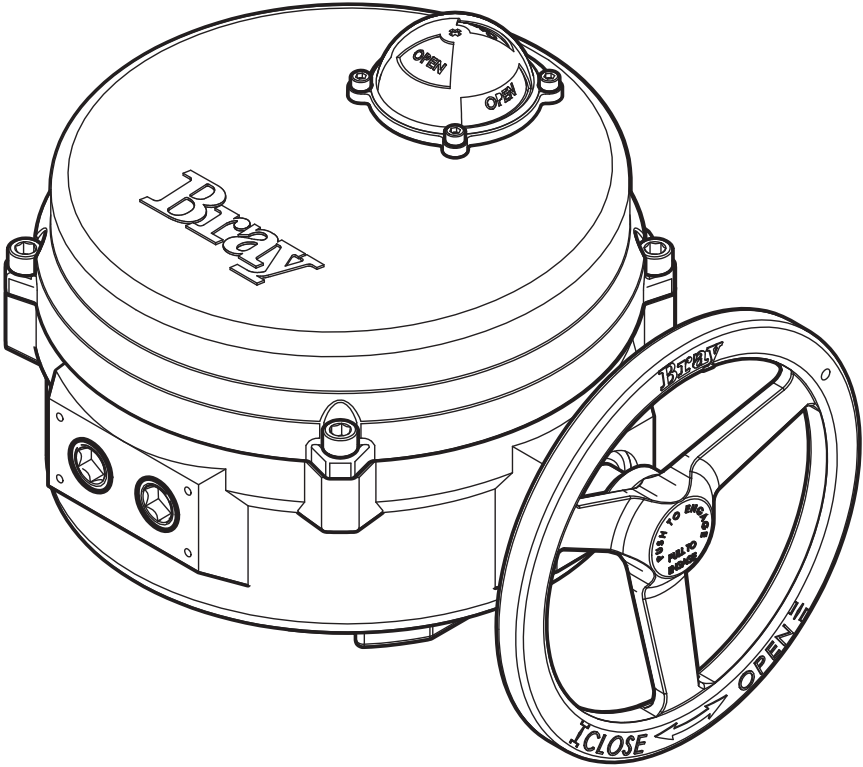

 **Bray**[®]

Declaration of Conformity

We,

Bray International, Inc.
13333 Westland East Blvd.
Houston, TX 77041
USA

Declare under our sole responsibility that the

Series 70 Electric Valve Actuators

and their derivatives are IP65 compliant and conform to the essential protection requirements of the

EMC Directive 2014/30/EU,

Machinery Directive 2006/42/EC, and

Low Voltage Directive 2014/35/EU.

Test Standards:

- EN 55011:2016/A1:2017
- EN 61326-1:2013
- EN 61000-3-2:2014
- EN 61000-3-3:2013
- EN 61000-4-2:2009
- EN 61000-4-3:2006+A2:2010
- EN 61000-4-4:2012
- EN 61000-4-5:2014
- EN 61000-4-6:2014+AC:2015
- EN 61000-4-8: 2010
- EN 61000-4-11:2004
- EN ISO 12100:2010
- EN 60034-1:2010
- EN 60204-1:2006+A1:2009
- EN 60529-2000

Issued in Houston

On January 24, 2018

Signed for on behalf of

Bray International, Inc.

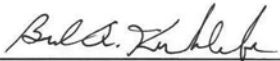
Signed 

Print Name Brad A. Kirchhofer

Position Chief Operating Officer



Table of Contents

Safety Instructions - Definition of Terms	2
Hazard-Free Use.	2
Qualified Personnel	2
Part Numbering System Reference Chart	3
Introduction.	3
Principle of Operation	3
Electrical Operation.	3
Mechanical Operation	3
Actuation	4
Manual Operation	4
Remote Operation	4
S70 On/Off Actuator with Interposing Relay Board (I.R.B.)	4
Servo NXT	5
Storage	6
Commissioning	6
Mounting the Actuator.	6
Wiring the Actuator	7
Setting Travel Limit Switches	7
Setting Mechanical Travel Stops	8
Disassembly and Assembly	10
Field or Factory Installable Options	13
Auxiliary Switches	13
Heater	13
Torque Switches	14
Local Control Station	14
Control Station Kit	14
Battery Backup Unit	15
Indication of Remote Control.	16
Spinner.	16
Receptacles (Quick Connectors)	16
External Signal Feedback Potentiometer	17
Appendix A	18
Basic Tools	18
Appendix B	19
Actuator Troubleshooting Chart	19
Series 70 – Size 003, 006 – Electric Actuator Exploded View	20
Series 70 – Size 008, 012, 020 – Electric Actuator Exploded View	22
Series 70 – Size 030, 050, 065 – Electric Actuator Exploded View	24
Series 70 – Size 130, 180 – Electric Actuator Exploded View	26
Series 70 – Size 130, 180 – 3:1 Gear Box Exploded View	28

**FOR MORE INFORMATION ON THIS PRODUCT AND OTHER BRAY PRODUCTS
PLEASE VISIT OUR WEBSITE – bray.com**

Safety Instructions - Definition of Terms

READ AND FOLLOW THESE INSTRUCTIONS
SAVE THESE INSTRUCTIONS

	WARNING	indicates a potentially hazardous situation which, if not avoided, could result in death or serious injury.
	CAUTION	indicates a potentially hazardous situation which, if not avoided, may result in minor or moderate injury.
NOTICE		indicates a potential situation which, if not avoided, may result in an undesirable result or state, including property damage.

Hazard-Free Use

This device left the factory in proper condition to be safely installed and operated in a hazard-free manner. The notes and warnings in this document must be observed by the user to ensure hazard-free operation of this device.

All necessary precautions need to be taken to prevent damage due to rough handling, impact, or improper storage. Do not use abrasive compounds to clean the device, or scrape its surfaces with any objects.

Configuration and setup procedures for this device are described in this manual. Proper configuration and setup are required for the safe operation of this device.

The control system in which this device is installed must have proper safeguards to prevent injury to personnel, or damage to equipment, should a failure of system components occur.

	WARNING
The device generates large mechanical force during normal operation.	

Qualified Personnel

	WARNING
The actuator must only be installed, commissioned, operated and repaired by qualified personnel.	
Installation, commissioning, operation and maintenance must be performed under strict observation of all applicable codes, standards and safety regulations.	

As per this document, a qualified person is one who is trained in:

- The operation and maintenance of electric equipment and systems in accordance with established safety practices.
- Procedures to energize, de-energize, ground, tag and lock electrical circuits and equipment in accordance with established safety practices.
- The proper use and care of personal protective equipment (PPE) in accordance with established safety practices.
- First aid.
- In cases where the device is installed in a potentially explosive (hazardous) location – is trained in the operation, commissioning, operation and maintenance of equipment in hazardous locations.

	WARNING
Reference is specifically made here to observe all applicable safety regulations for actuators installed in potentially explosive (hazardous) locations.	

Part Numbering System Reference Chart

SERIES	TORQUE CODE	SPEED	PRODUCT	STYLE	VOLTAGE	TRIM
70	AAA	X	113	Y	Z	TTT

ACTUATOR SIZE	PART NUMBER	TORQUE In.Lbs	TORQUE Nm	SPEED, ¼ TURN Seconds	SUPPLY Z Voltage
S70-003	70-003X-113YZ-TTT	300	34	30/15	0/2/4
S70-006	70-006X-113YZ-TTT	600	68	30	0/2/3/4
S70-008	70-008X-113YZ-TTT	800	90	30/15/6	0/2/4
S70-012	70-012X-113YZ-TTT	1200	136	30/15/6	0/2/4
S70-020	70-020X-113YZ-TTT	2000	226	30/15	0/2/3/4
S70-030	70-030X-113YZ-TTT	3000	339	30/18	0/2/4
S70-050	70-050X-113YZ-TTT	5000	565	30/18	0/2/3/4
S70-065	70-065X-113YZ-TTT	6500	734	30	0/4
S70-130	70-13WX-113YZ-TTT	13000	1469	110	0/4
S70-180	70-18WX-113YZ-TTT	18000	2034	110	0/4

Use this chart as a guide to interpret the S70 electric actuator part number.

Note: Not all combinations are possible.

YZ - STYLE / VOLTAGE:

Imp.	Metric	
DA	NA	120VAC Interposing Relay Board
DB	NB	220VAC Interposing Relay Board
DC	NC	24VAC On/Off with Controller
DD	ND	24VDC On/Off with Controller
AA	MA	120VAC Modulating with Servo Pro
AB	MB	220VAC Modulating with Servo Pro
AC	MC	24VAC Modulating with Servo Pro
AD	MD	24VDC Modulating with Servo Pro
G0	R0	120VAC Modulating with Servo NXT
G2	R2	24VDC Modulating with Servo NXT
G3	R3	24VAC Modulating with Servo NXT
G4	R4	220VAC Modulating with Servo NXT

NOTE: 220VAC units are 230VAC compatible

W - DESIGNATES THE OUTPUT BORE DIAMETER

0	2.5 Inches [63.5 mm]
1	1.97 Inches [50 mm]

X - DESIGNATES THE SPEED

X:	0	1	2	6
Sec:	60	30	15/18	110

Y - DESIGNATES THE STYLE

Imp.	Metric	
G	R	Servo NXT
D	N	I.R.B. On/Off
A	M	Servo Pro

Z - DESIGNATES THE VOLTAGE

Z:	0	2	3	4
	A	D	C	B
Voltage:	120VAC	24VDC	24VAC	220VAC

TTT - DESIGNATES THE PRODUCT TRIM

536	Standard Bray Red
5F5	Bray Seacorr Coating

Units of measure designation = Imperial [Metric]

Introduction

The Bray Series 70 is a quarter turn electric actuator with manual override for use on any quarter turn valve requiring up to 18000 in-lb [2034 Nm] of torque. Operating speeds vary between 15 to 110 seconds.

Principle of Operation

The Series 70 actuator is divided into two internal sections, the power center below the switch plate, and the control center above the switch plate. Below the switch plate, the gear motor, with its spur gear train, drives a non-backdrivable worm gear output. The override mechanism for manual operation is also housed here. Above the switch plate is where user required readily accessible components are placed. The indicator shaft assembly, limit switches, terminal strips, torque switches, heater, and electronic controllers are all placed here for easy access.

External to the unit are adjustable mechanical travel stops, a large and easy to read indicator, the unique manual override handwheel, and dual conduit entry ports. The external coating is a high-quality polyester powder coat which has exceptional UV protection and chemical resistance.

Electrical Operation

The gear motors used in the Bray Series 70 are of either permanent split capacitor (PSC) design (single phase AC power) or permanent magnet (PM) design

(DC power). Travel limit switches are mechanical form (SPDT) with contacts rated at 10 Amp (0.8 PF), 1/2 HP 125/250 VAC.

In cases where the torque capacity of the unit is exceeded to the point where the motor stalls, a thermal protector switch, built into the PSC motor windings, will automatically disconnect the motor power and prevent overheating. Once the motor cools sufficiently, the thermal protector switch will reset automatically.

Optional torque switches are available in all units to prevent the possibility of stalling the motor, thus reducing the possibility of an inoperable thermal cool down period. Torque switches, installed by Bray, are factory adjusted to the output torque rating of the unit using electronic torque testing equipment.

Mechanical Operation

Mechanically, the ratio of the gear motor determines the speed of the unit. The gear motor utilizes high efficiency spur gears with various ratios for the different speeds. Initial gear reduction through the spur gears is then transferred to the worm shaft. The final gear reduction and output is through a non-backdrivable worm gear set. Positioning is determined by an indicator/cam shaft, which is linked to the output shaft. In the declutchable condition, the manual override drives the worm shaft when engaged.

Actuation

Manual Operation

The manual override operates similar to a watch adjusting knob. To engage the manual override, simply pull the handwheel to its outermost position. A yellow stripe is revealed to visually indicate manual override engagement as shown in Figure 1. The two handwheel positions, engaged and disengaged, are held in place with the use of spring plungers. The handwheel remains in position until physically moved.

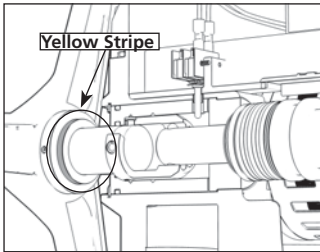

Figure 1 - Handwheel is engaged, revealing the yellow stripe.

Once the manual override is engaged, rotating the handwheel in the clockwise direction will rotate the output shaft in the clockwise (close) direction and vice-versa.

To disengage the manual override, the handwheel needs to be pushed towards the actuator until the 'yellow stripe' is hidden.



CAUTION

A label on the handwheel hub warns users not to exceed a specific 'rim pull' force, for each size of actuator.

If the 'rim pull' force is exceeded, the roll pin securing the handwheel onto the manual override shaft is designed to shear, thus preventing serious internal gearing damage.

Remote Operation



CAUTION

1. Verify that the main electric power supplied to the actuator is in compliance with the specifications on the actuator label.
2. Engaging the handwheel before or during the application of a supply voltage will prevent the actuator motor from operating.
3. If torque switches are installed in the actuator, an over-torque condition will prevent the actuator motor from operating in the direction of fault.

S70 On/Off Actuator with Interposing Relay Board (I.R.B.)

The back feeding of one actuator by another one wired in parallel is eliminated by using the I.R.B. If actuator is running Open and customer switches "instantaneously" to run Closed, the Open relay will take time to 'drop-out' and the Close relay will take time to 'pull-in' this time lapse is ~ 40ms. The time delay provided by the I.R.B. will protect the switches and gears from the controller's instantaneous command signal reversal. Current draws and field wirings are not affected by adding I.R.B.

S70 120VAC I.R.B., auxiliary switch, heater, and torque switch option are UL certified units

NOTE: The host controller should use a one second time delay for command signal reversal.



CAUTION

Apply voltage to only one direction terminal at a time.

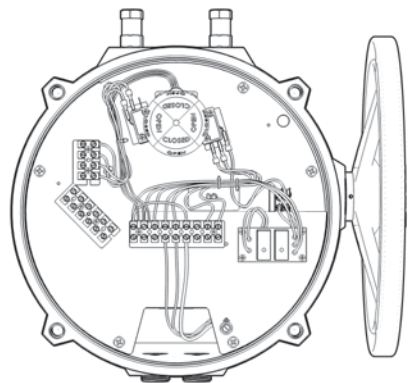
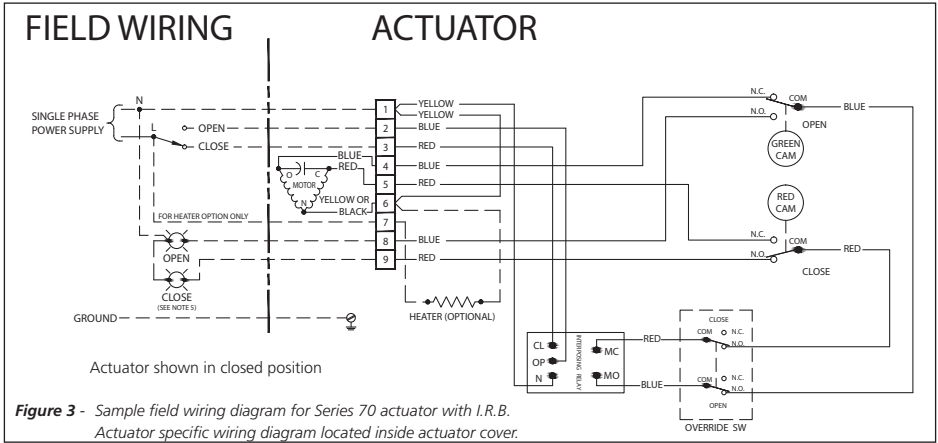

Figure 2 - S70 with I.R.B.



Servo NXT

To control the actuator remotely from a process controller in a modulating application, user must apply the proper supply voltage and the configured control signal to the Servo NXT electronics package. The control signal may be applied locally from a hand-held signal generator or remotely from a process controller.

For more information, please refer to the S70 Servo NXT Manual. This manual is available on the company website (bray.com).

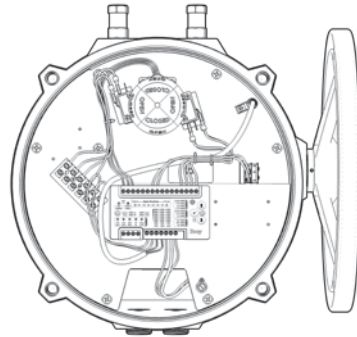
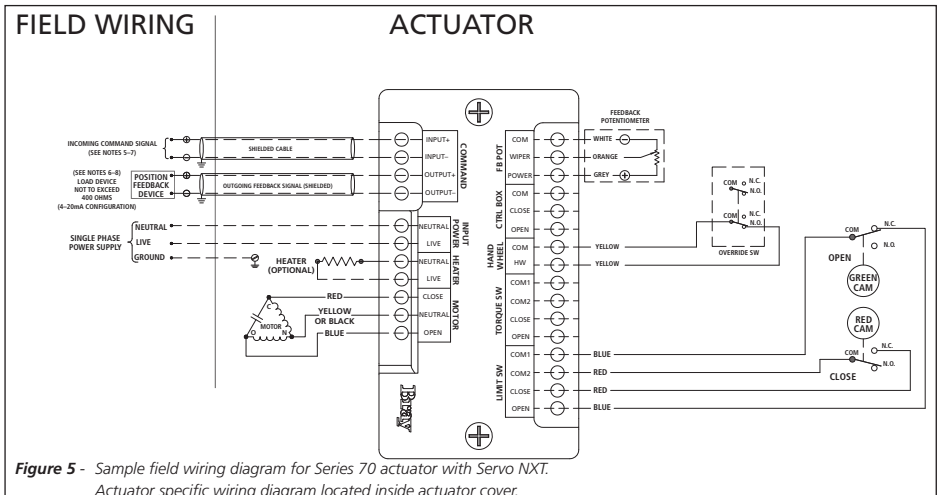

Figure 4 - S70 with Servo NXT



Storage



WARNING

Actuators are not weatherproof unless they are properly installed on the valve or prepared for storage. Bray cannot accept responsibility for deterioration caused on-site.

- Store units on a shelf or wooden pallet in order to protect against floor dampness.
- Cover the units to protect against dust and dirt.
- To prevent condensation from forming inside these units, maintain a near constant external temperature and store in a well-ventilated, clean, dry room away from vibration.
- For units with an internal heater, power should be supplied to the heater via conduit entry with an appropriate sealing gland.

Commissioning

Mounting the Actuator

All Bray Series 70 electric actuators are suitable for direct mounting on Bray butterfly valves. With proper mounting hardware, the S70 actuator can be installed onto other quarter-turn valves or devices.

NOTICE

The standard mounting position for the actuator orients the unit with its handwheel in a vertical plane and parallel to the pipeline.

If the actuator is mounted on a vertical pipe, it is recommended that the unit be positioned with the conduit entries on the bottom to prevent condensation from entering the actuator through its conduits.

In all cases, the conduit should be positioned to prevent drainage into the actuator and the handwheel should not be facing down.

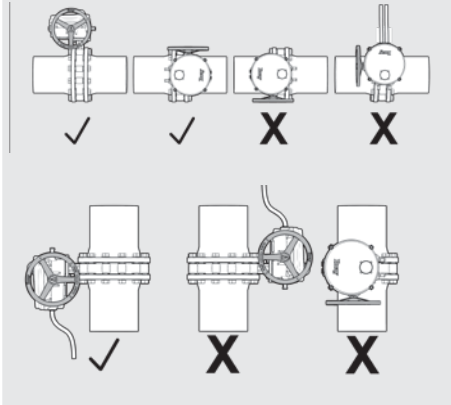

Follow the steps below to mount the actuator onto the valve.

1. Manually operate the actuator until the output shaft of the actuator is in line with the valve stem. If possible, select an intermediate position for both the valve and actuator.
2. If required, place the proper adapter onto the valve stem. It is recommended that a small amount of 'anti-seize' lubricant be applied to the adapter to ease assembly.
3. Mount the actuator onto the valve stem.
4. Install the furnished mounting studs by threading studs all the way into the actuator base. It may be necessary to manually operate the actuator to align the valve and actuator bolt patterns.
5. Fasten the mounting studs in place with furnished hex nuts and lock washers

Wiring the Actuator



WARNING

Turn off all power and lockout/tag out service panel before installing or modifying any electrical wiring.

1. Take the actuator cover off. The cover should be kept on hand for reference.
2. Wire the actuator as per the wiring diagram attached to the inside of the actuator cover.

NOTICE

Power and control wiring should use separate conduit entries.

NOTICE

A minimum of 18 AWG wire is recommended for all field wiring.

Terminals directly mounted on the actuator switch plate accept wire sizes ranging from 14 to 22 AWG.

Terminals of internally mounted electronics modules accept wire sizes ranging from 14 to 24 AWG.

NOTICE

The conduit connections must be properly sealed to maintain the weatherproof integrity of the actuator enclosure.

Setting Travel Limit Switches

NOTICE

If the unit came assembled to a valve, the switches have been factory-set and DO NOT need adjustment.

Bray uses its patented cam design along with two SPDT mechanical switches to set the 'Open' and 'Closed' position of the valve. The green cam actuates the 'open' switch when the actuator reaches the 'open' position. Similarly, the red cam actuates the 'closed' switch when the actuator reaches the 'closed' position.

Standard factory setting of the travel limit switches allows 90° travel between open and close positions. Cams for each switch are adjustable for applications where less than 90-degree travel is desired between the open and closed positions.

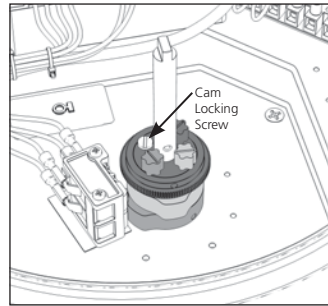

Figure 6. Two SPDT Travel Limit Switches

Follow the steps below to adjust the travel limit cams.

NOTE: For Actuator Size 130, 180, ignore steps 1 and 10.

1. Remove the indicator rotor by pulling away from the indicator shaft as shown in Figure 7.

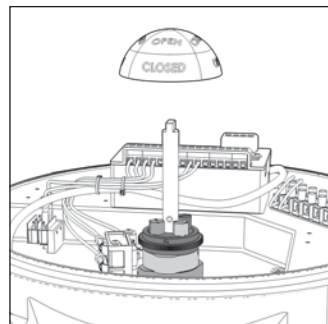

Figure 7. Indicator rotor pulled up from the indicator shaft.

2. Manually operate the actuator clockwise until the valve reaches the desired 'closed' position.
3. Loosen the cam locking screw shown in Figure 6.

NOTICE

Cam locking screw must be slackened before cam adjustments and re-tightened after cam adjustments.

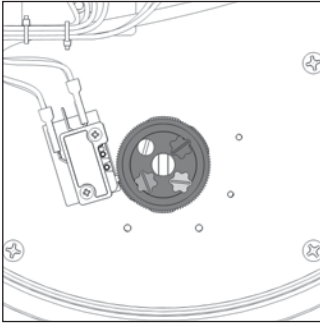

Figure 8. Top view of the indicator shaft.

NOTE: It is possible that the rotation of one cam will move the other cam. If this occurs, hold the other knobs or cams during adjustment.

4. Rotate the red cam adjustment knob by hand or with a flat head screwdriver until the red cam lobe just activates (depresses) the 'closed' switch from a clockwise direction.

NOTE: If fixed auxiliary switches are installed, the auxiliary cam will activate prior to the main cam.

5. Tighten the cam locking screw.
6. Manually operate the actuator counterclockwise until the valve reaches the desired 'open' position.
7. Loosen the cam locking screw.
8. Rotate the green cam adjustment knob until the green cam lobe activates (depresses) the 'open' switch from a counterclockwise direction.
9. Tighten the cam locking screw.
10. Place the indicator rotor back on the indicator shaft.

Setting Mechanical Travel Stops

NOTICE

If the unit came assembled to a valve, the stops have been factory-set and **DO NOT** need adjustment.

Mechanical travel stops are designed to prevent over travel while manually operating the actuator. They are not designed to stop the electric motor.

Mechanical travel stops are located outside of the actuator base for easy readjustment. Stainless steel lock nuts with O-ring seals hold the travel stops securely in place. Travel stop spacers are used to ensure that travel stop bolts are not engaged to where they could limit 0° to 90° electrical operation.

NOTE: Actuator Size 130, 180 does not use travel stop spacers.

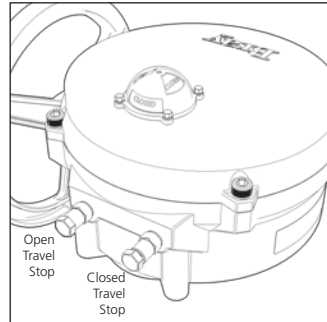

Figure 9. Mechanical Travel Stops (CW Close).

Follow the steps below to set the mechanical travels stops.

1. Manually drive the actuator to the 'closed' position.
2. Once the actuator is in the 'closed' position, rotate the handwheel clockwise:
 - ½ turn for Actuator Size 003, 006.
 - 1 turn for Actuator Size 008, 012, 020.
 - ½ turn for Actuator Size 030, 050, 065.
 - 2 turns for Actuator Size 130, 180.
3. Adjust the 'closed' travel stop bolt until the travel stop spacer is fully engaged or the travel stop bolt contacts the output segment gear.

4. Lock the travel stop bolt in position with the locknut.
5. Manually drive the actuator to the 'open' position.
6. Once the actuator is in the 'open' position, rotate the handwheel counterclockwise
 - ½ turn for Actuator Size 003, 006.
 - 1 turn for Actuator Size 008, 012, 020.
 - ½ turn for Actuator Size 030, 050, 065.
 - 2 turns for Actuator Size 130, 180.
7. Adjust the 'open' travel stop bolt until the travel stop spacer is fully engaged or the travel stop bolt contacts the output segment gear.
8. Lock the travel stop bolt in position with the locknut.

Disassembly and Assembly



WARNING

Turn off all power and lockout/tag out service panel before installing or modifying any electrical wiring.

1. Disconnect external wiring from terminals.
2. Disconnect motor wires from the main terminal strip (motor neutral, open, and close)

NOTICE

Removal of switch plate with torque switches will void warranty.

3. To remove the switch plate:
 - a. Follow after disconnecting external wires and motor wires.
 - b. Unscrew the seven Phillips head mounting screws.
 - c. Lift the switch plate(s) out as an assembly with the indicator shaft attached.
 - d. **NOTE:** Do not misplace shaft coupler, insert, or mounting screws.

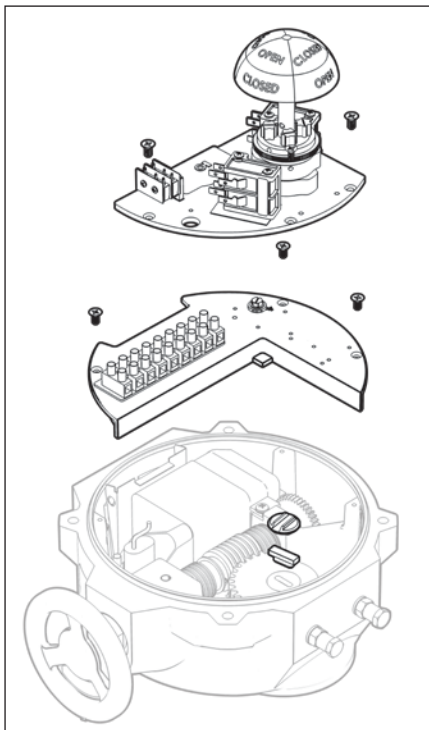

Figure 10. S70, Actuator Size 003, 006 – switch plate removed.

4. To replace the switch plate:
 - a. Engage handwheel.
 - b. Place insert into the worm segment.
 - c. Place and center shaft coupler onto insert.
 - d. Align indicator shaft with groove in coupler and gently place switch plate into position.
 - e. Check alignment of override switch activation pin.
 - f. Slowly turn handwheel to ensure that the indicator shaft is fully engaged in coupler.
 - g. Secure the switch plate with seven Phillips head mounting screws in a “star” pattern.
 - h. Disengage the handwheel.
5. To remove the indicator shaft from the switch plate:
 - a. Follow after removing the switch plate.
 - b. Remove the retaining ring from the shaft, located underneath switch plate.
 - c. Press the shaft out, from the bottom of the switch plate.
 - d. **NOTE:** Provide support to top of switch plate so that components on top of the switch plate are not damaged during this procedure.
6. To remove the bearing from the switch plate:
 - a. Follow after the removing the indicator shaft.
 - b. Press the bearing from the top of the switch plate to remove the bearing.
 - c. To replace, press bearing (700000-72701534) into switch plate from the bottom of switch plate.
7. To replace the indicator shaft in the switch plate:
 - a. Gently press the indicator shaft from the top of the switch plate until the cams are flush with the top surface of the switch plate. **NOTE:** Provide support for the press fit bearing during this step.
 - b. Replace retaining ring (070375-74503534) on the shaft, located underneath switch plate.
 - c. Gently press the indicator shaft from the bottom until the retaining ring is flush with bottom of the bearing.
 - d. Test indicator shaft for tight fitment and ease of rotation.
8. Other switch plate components:
 - a. Most components can be removed from the switch plate without removal of the switch plate.

NOTE: Override switch assemblies are typically only removable after the switch plate has been removed. A specialty (short or 90°) screwdriver could be used for disassembly when the switch plate is still attached to the actuator base.

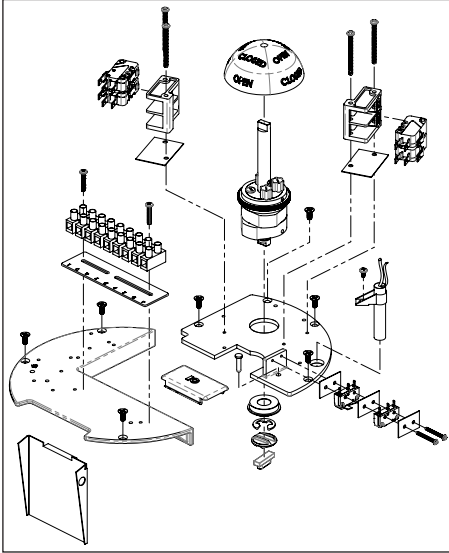

Figure 11. S70, Actuator Size 003, 006 – switch plate exploded view.

9. To remove the gear motor:
 - a. Follow after removing the switch plate.
 - b. Disconnect the motor leads which run to the capacitor (120/220VAC motors).
 - c. For Actuator Size 003, 006, unscrew the mounting screws (two lower, one upper).
 - d. For Actuator Size 008, 012, 020, unscrew the mounting screws (four lower, one upper).
 - e. For Actuator Sizes 030 - 180, unscrew the mounting screws (five lower, one upper).
 - f. Remove the motor vertically out of the unit.

NOTE: Do not misplace the alignment pin(s), mounting screws or lockwashers.
10. To replace the gear motor:
 - a. Replace alignment pin (070612-71904520).
 - b. Place motor into housing and align motor with worm shaft spur gear.
 - c. Secure the motor with mounting screws and lockwashers in a “star” pattern.
 - d. Manually operate actuator to ensure proper alignment.
 - e. Connect motor leads to capacitor (PSC motors only).

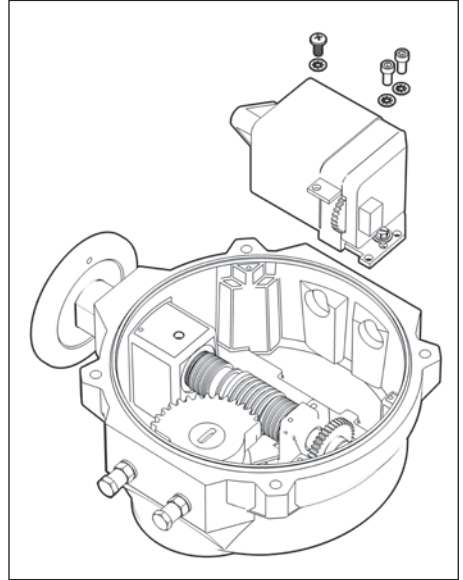

Figure 12. S70, Actuator Size 003, 006 – motor removed.

11. To remove the worm shaft spur gear:
 - a. Follow after removing the gear motor.
 - b. For Actuator Size 003, 006:
 - i. Remove spring pin using a 3/32” [2.0 mm] punch.
 - ii. Slide the gear off the end of the worm shaft.
 - c. For Actuator Size 008, 012, 020:
 - i. Remove spiral retaining ring
 - ii. Remove dowel pin with 3/16” [4.5 mm] punch.
 - iii. Slide the gear off the end of the worm shaft.
 - d. For Actuator Sizes 030 - 180:
 - i. Remove bowed E-clip retaining ring.
 - ii. Slide the gear off the end of the worm shaft.
 - iii. Remove key
12. To replace the worm shaft spur gear:
 - a. Slide the gear onto the end of the worm shaft.
 - b. For Actuator Size 003, 006:
 - i. Slide the gear (700006-75511520) onto the end of the worm shaft.
 - ii. Align the mounting hole on the gear and the shaft.
 - iii. Use a 3/32” [2.0 mm] punch to replace the slot spring pin (070412-71900520).
 - c. Actuator Size 008, 012, 020:
 - i. Slide the gear (700012-75511520) onto

- the end of the worm shaft.
 - ii. Align the mounting hole on the gear and shaft.
 - iii. Use a 3/16" [4.5 mm] punch to replace the dowel pin (070612-71804520).
 - iv. Replace the spiral retaining ring (070812-74518520).
 - d. Actuator Sizes 030 - 180:
 - i. Rotate the handwheel so that the keyway is visible and facing upwards.
 - ii. Replace key (700030-73100901).
 - iii. Slide the gear (700030-75503520) onto the worm shaft.
 - iv. Replace bowed E-clip retaining ring (070625-74511529).
13. To remove the output drive worm wheel:
- a. Follow after removing the switch plate.
 - b. Back off both mechanical travel stops.
 - c. Remove the retaining ring and thrust washer from the bottom of the base.
 - d. Lift the output drive worm wheel out of its base.

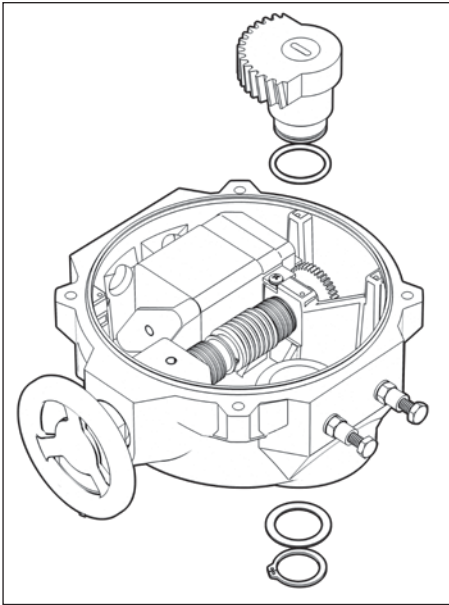

Figure 13. S70, Actuator Size 003, 006 – output drive worm wheel and spur gear removed.

14. To replace the output drive worm wheel:
- a. Ensure worm wheel contains o-ring and is in good condition.
 - b. Ensure that o-ring and worm wheel teeth are

lubricated with grease.

- c. Place the worm wheel into the base, meshing teeth with worm gear.
 - d. Replace thrust washer and retaining ring.
 - e. Engage handwheel and manually drive worm wheel to ensure smooth operation.
 - f. Reset mechanical travel stops after switch plate has been replaced.
15. To remove the handwheel:
- a. Engage the handwheel.
 - b. Use a punch to remove the slot spring pin.
 - i. Actuator Size 003, 006: 3/32" [2.0 mm] punch
 - ii. Actuator Size 008 - 180: 1/8" [3 mm] punch
 - c. Slide the handwheel off of the override shaft.

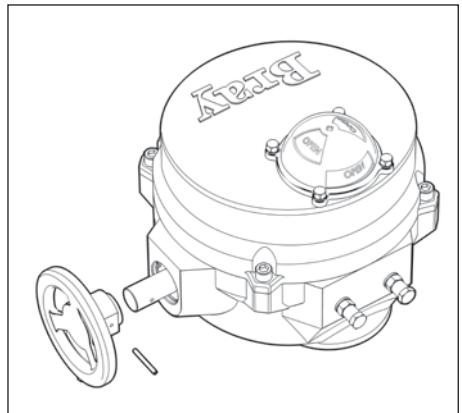

Figure 14. S70 with handwheel removed.

16. To replace the handwheel:
- a. Engage the override shaft.
 - b. Slide the handwheel onto the override shaft and align mounting holes.
 - c. Use a punch to fit a replacement slot spring pin.
 - i. Actuator Size 003, 006 slot spring pin: 070316-71900529
 - ii. Actuator Size 008, 012, 020 slot spring pin: 070424-71900534
 - iii. Actuator Size 030, 050, 065-180 slot spring pin: 070428-71900534
 - d. Disengage the handwheel.



CAUTION

Further disassembly of the unit requires special tools and procedures, and thus will not be covered in this manual.

Field or Factory Installable Options

Auxiliary Switches

Auxiliary switch kits are a field or factory installable option for all Series 70 actuators. Switch kits are comprised of dry-contact (voltage free) SPDT mechanical switches which are used to indicate travel position. Switches are arranged into 2 stacks. For Actuator Size 003 - 065, stack 2 activates 3° prior to switches in stack 1. For Actuator Size 130, 180, the switch that activates 3° early depends on the direction of travel.

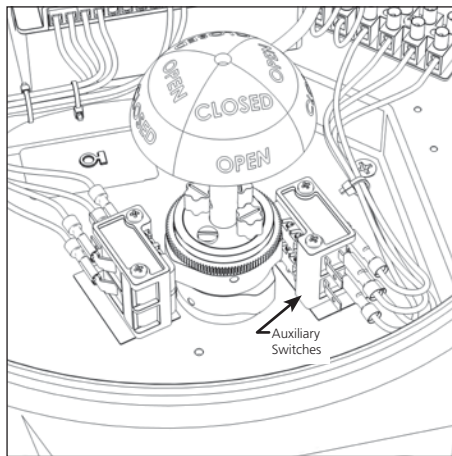

Figure 15. Fixed auxiliary switches installed in a S70 actuator.

All Series 70 actuators can be fit with one set of fixed auxiliary switches. These are a single set of switches which activate 3° before the travel limit switches. Adjustable auxiliary (Mid-Travel) switches can be fit as single independent switches or in sets. If fitted as a set, one of the switches in the set will activate 3° before the other. Each switch set is activated independently from other switch sets.

The maximum number and configuration of switches depends on Actuator size and application of the Series 70 actuator. Terminal block availability due to installation of other options may also limit the maximum number of switches.

Switch Config. for Modulating Application	Actuator Size 003, 006	Actuator Size 008 thru 065	Actuator Size 130, 180
2 Limit Switches	Standard	Standard	N/A
2 Limit, 2 Fixed	70A000-22901536	70A000-22901536	Standard
2 Limit, 2 Fixed, 1 Mid	70A006-22912536	70A012-22912536	70B180-22912536
2 Limit, 2 Fixed, 2 Mid	N/A	N/A	N/A
2 Limit, 2 Fixed, 1 Set Mid	N/A	70A012-22914536	70B180-22914536
2 Limit, 2 Fixed, 2 Set Mid	N/A	N/A	N/A

Switch Config. for On/Off Applications	Actuator Size 003, 006	Actuator Size 008 thru 065	Actuator Size 130, 180
2 Limit Switches	Standard	Standard	N/A
2 Limit, 2 Fixed	70A000-22901536	70A000-22901536	Standard
2 Limit, 2 Fixed, 1 Mid	70A006-22902536	70A012-22902536	70B180-22902536
2 Limit, 2 Fixed, 2 Mid	70A006-22903536	70A012-22903536	70B180-22903536
2 Limit, 2 Fixed, 1 Set Mid	70A006-22904536	70A012-22904536	70B180-22904536
2 Limit, 2 Fixed, 2 Set Mid	N/A	70A012-22905536	70B180-22905536

Heater

Bray offers an optional heater as a field or factory installable option for the Series 70 actuator to prevent condensation from forming inside the actuator. This PTC (Positive Temperature Coefficient) style heater has a unique temperature - resistance characteristic. The heater self-regulates by increasing its electrical resistance relative to its temperature. The heater does not require external thermostats or switches to control its heat output.

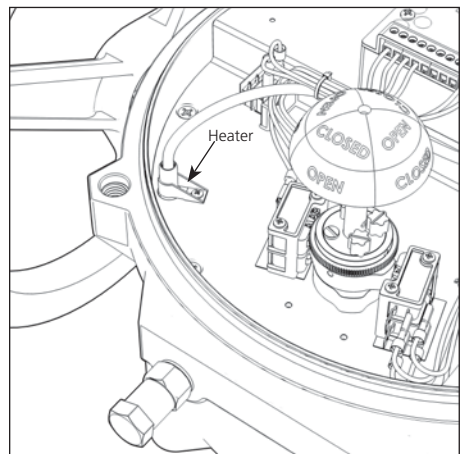

Figure 16. Heater installed on a S70 switch plate.

NOTICE

The heater must have a constant power supply to be effective



WARNING

The heater surface can reach temperatures in excess of 392°F [200°C].

Heater Kit:

- Heater with flying leads
- Mounting Bracket
- #10 Pan Head Screw, Phillips Drive

Tools Required:

- Screwdriver, 3/16" [5 mm] tip flat blade
- Screwdriver, No.1 Phillips

Installation Procedure:



WARNING

Turn off all power and lockout/tag out service panel before installing or modifying any electrical wiring.

The heater is mounted through a hole provided in the switch plate.

1. Place the heater snugly into its mounting bracket until approx. 1/2 to 1" [13mm to 25 mm] is left above the bracket.
2. Slip the heater into its mounting hole.
3. Align the fastening hole in the bracket with the threaded screw hole in the plate and fasten the heater to the switch plate.
4. Connect the heater wires to the terminal strip as indicated on the wiring diagram.

Torque Switches

Mechanical Torque switches are a factory installed and calibrated option available for all Series 70 actuators. Installation is simple, but due to the requirement for special calibration equipment, it is not available for field installation. Modifying the factory torque setting voids the actuator warranty. Removal of the switch plate invalidates factory calibration

The worm is pinned to the worm shaft, which is held in position with a stack of disc springs at both ends. The torque transmitted through the worm to the output worm gear acts directly against the disc springs, which compress proportionately. The worm and worm shaft shift axially as a result.

A specially designed drive lever and pin is incorporated into a groove on the worm, providing the profile for the torque switching mechanism. A drive lever & pin rides in the worm gear torque sensor groove, and in turn drives a cam. The cam then actuates its electrical switch, which interrupts the power to the motor winding when the torque exceeds the setting. The motor can still be powered to run in the opposite direction. When powered in the opposite direction, the tripped torque switch will release automatically.

NOTICE

Torque switches are not field adjustable. Adjustment of torque switches in the field will void warranty.

Removal of switch plate with torque switches in the field will void warranty.

Local Control Station

The local control station is a field or factory installable option that gives the operator the ability to locally drive the Series 70 actuator with electrical power; overriding the control signal from the process controller. The control station has a red (closed) and green (open) light to provide end-of-travel indication. It also has two 3-position switches as shown in Figure 17.

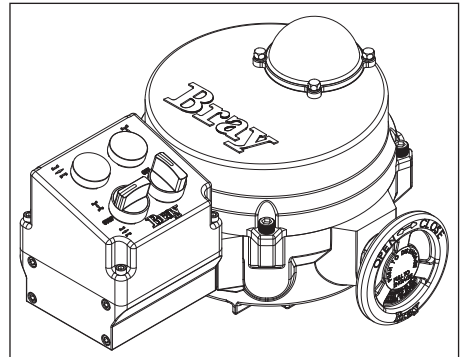

Figure 17. S70 with Control Station.

Switch 1 lets the operator choose between the following three modes of operation:

1. **Local:** In this mode, using switch 2 the operator can drive the actuator to open or close position, or stop the actuator; overriding any control signal from the process controller.
2. **Off:** In this mode, the actuator can only be operated manually.
3. **Remote:** In this mode, the actuator is controlled remotely from a process controller.

Control Station Kit

- Local Control Station Assembly
- #10-24UNC x 4.5" Socket Head Cap Screws (Qty:4)
- O-rings (Qty:4)
- Gasket
- Wiring Diagram

Tools Required:

- Screwdriver, 3/16" [5 mm] tip flat blade
- Screwdriver, No.1 Phillips
- Hex Key, 5/32"

Installation Procedure:



WARNING

Turn off all power and lockout/tag out service panel before installing or modifying any electrical wiring.

The local control station is mounted to the S70 against the conduit openings using 4 pre-drilled and tapped mounting holes.

1. Remove the S70 actuator cover and set aside in a safe location.
2. Remove all conduit plugs and external connections on the S70 that may already be in place.
3. Remove 4 short bolts and washers that were pre-installed on the exterior of the S70 base, surrounding the conduit entries.
4. Adhere the gasket to the control station base.
5. Slide o-rings onto the long mounting bolts until flush with bottom of bolt head.
6. Mount the control station to the actuator using the 4 mounting bolts.
7. Wire the control station to the actuator in accordance to the wiring diagram provided.

NOTICE

Power and control wiring should use separate conduit entries

NOTES:

- The local control station contains no terminal strips and all wiring is direct to the switches and lights via 2 x 3/4" NPT or holes in bottom of housing.
- Ordering the control station with optional pin connector receptacles will eliminate the necessity of field wiring. Not all possible options are available with receptacles. Consult factory.
- Control station will be completely factory wired and tested.
- Factory will need wiring diagram drawing number of the existing unit if it is to be retrofit with a local control station. New wiring diagram will be provided based upon this information.
- Local control station can be ordered with key lockable switches.
- Local control station requires a dedicated set of auxiliary switches. These switches are required for turning on or off the lights on the control station to locally indicate actuator position.

- Alternative mounting kit can be ordered in case it is preferred to mount the control station nearby but not on the S70 actuator.

Battery Backup Unit

Bray offers a factory installable Battery Backup Unit (BBU) for the 24 V Series 70 electric actuator.

In the event of power failure, the BBU will switch the actuator to battery power to reach its fail position. After the actuator has reached its fail position, the BBU goes to 'Standby Mode' until external power is restored.

Once external power has been restored, the actuator returns to the position corresponding to the control signal present.

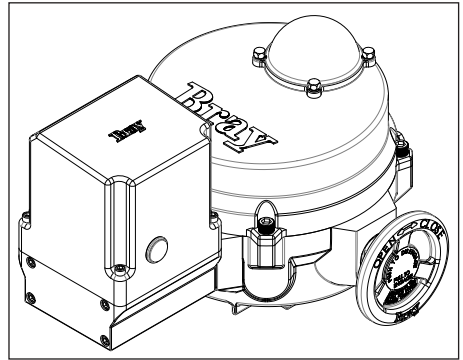

Figure 18. S70 with Battery Backup Unit.

Battery Backup Unit is available as a factory installable option. For more information, please refer to the S70 24V Actuator with BBU Manual. This manual is available on the company website (bray.com).

Indication of Remote Control

Bray offers two field or factory installable kits to indicate if a process controller has remote control of the Series 70 actuator. Remote control of the actuator can be interrupted if the actuator handwheel has been left engaged or if a local control station has been switched out of remote mode.

A dry contact (voltage free) mechanical switch provides indication if the handwheel is engaged. Alternatively, an additional dry contact (voltage free) mechanical switch can be placed in Local Control Station to provided indication if the local control station is switched out of remote mode. Both kits can be installed and wired in series to provide dual indication. Dual indication wiring is meant to indicate that remote control has been interrupted and does not distinguish between modes of interruption.

NOTE:

- Factory will need wiring diagram drawing number and model of the existing unit if it is to be retrofitted with a Remote Control Indication kit. New wiring diagram will be provided based upon this information.
- Some configurations may limit use of remote control indication kits receptacles due to number of wires entering through the conduit.

Spinner

A spinner is field or factory installable attachment to the actuator handwheel to ease and speed the manual operation of the Series 70 actuator. Actuator Size 003, 006 units mount the spinner on a lever which screws onto the back of the handwheel. Actuator Size 008 - 180 units mount the spinner on the rim of the handwheel.

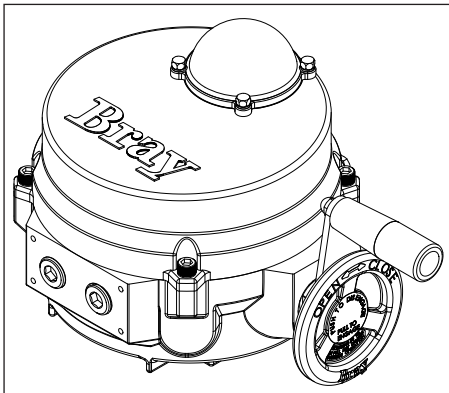

Figure 19. S70 with Handwheel Spinner Attached.

NOTICE

Care should be exercised in the use of a spinner equipped handwheel.

Rapid operation of the handwheel to close the valve may cause water hammer.

Rapid travel into a travel stop may cause damage.

Spinner Kit, Actuator Size 003, 006:

- Spinner and Lever Assembly
- #10-32UNF x 3/8" Flat Head Socket Cap.

Spinner Kit, Actuator Size 008 - 180:

- Spinner Handle
- 1/4"-20UNC x 3/4" Socket Head Shoulder Bolt

Tools Required:

- Hex Key, 1/8" (Actuator Size 003, 006)
- Hex Key, 3/16" (Actuator Sizes 008 - 180)

Installation Procedure:

- For Actuator Size 003, 006 – Position the lever onto the back of the handwheel then screw the flat head cap screw in to place from behind.
- For Actuator Size 008, 012, 020-180 – Place the socket head shoulder bolt through the spinner handle and screw it firmly into the handwheel rim.

Receptacles (Quick Connectors)

Bray offers plug-in receptacles as a field or factory option for quick and easy field wiring of Series 70 actuators. Cord sets to fit these connectors can also be ordered in several lengths.

Unless otherwise specified, power receptacles will be 5-pin mini style, standard duty with a black anodized aluminum finish. They conform to ANSI B93.55M except in wire color. Euro receptacles will be used for low power instrument and signal cable since they can be supplied shielded.

Wiring diagrams for plug-in receptacles for either the Bray Series 70 or the local control station will be provided as a separate diagram. Units ordered with pin connector receptacles factory installed are wired and tested

Receptacle Kit:

- Receptacle(s), male pin and male thread 1/2" NPT [M20], in the quantity, style, and number of pins ordered
- Reducing bushing 3/4" to 1/2" NPT [M25 to M20] for installation in Actuator Sizes 008 - 180 and control stations
- Wiring Diagram

Tools Required:

- Screwdriver, 3/16" [5 mm] tip flat blade
- Wrench, 1" [25mm]

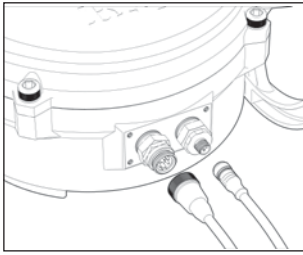

Figure 20. S70 with 5-pin receptacle and corresponding cord set.

Installation Procedure:

1. Screw the receptacle into the actuator conduit entry using Teflon tape or similar.
2. Wire to the terminal strip according to the wiring diagram or the field wiring requirements.

NOTES:

- Euro receptacles use 22 AWG wire rated at 250V, 4 Amp. Pin configuration interfaces with European standards.
- Mini Receptacles use 18 AWG wire rated at 300V, 9 Amp. Pin configuration conforms to ANSI B93.55M.
- Factory will need wiring diagram drawing number and model of the existing unit if it is to be retrofit with receptacles. New wiring diagram will be provided based upon this information.
- Some configurations may limit use of receptacles due to number of wires entering through the conduit.

External Signal Feedback Potentiometer

Potentiometers are a field or factory installable option for continuous duty actuators. Actuators which are not continuous duty do not have a pot gear fitted on their indicator shafts and must be fitted with a new indicator shaft in the factory. S70 actuators fitted with electronics for modulating applications already fit a potentiometer and cannot fit a second. In this case, retransmission of position is provided through the modulating electronics package.

Feedback Potentiometer Kit:

- Potentiometer Assembly
- #6 Cross Drive Pan Head Screws (Qty:2)
- #6 Internal Lockwashers (Qty:2)
- 4-pole Terminal Strip
- Terminal Strip Marker
- Wiring Diagram

Tools Required:

- Screwdriver, 3/16" [5 mm] tip flat blade
- Screwdriver, No.2 Phillips

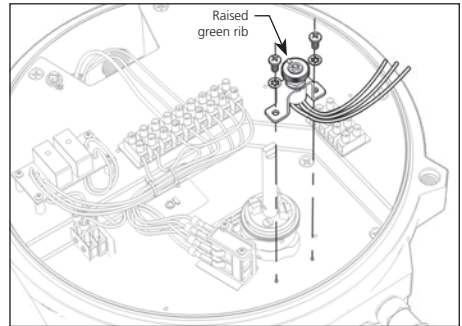

Figure 21. S70 Potentiometer installation.

1. Orient the actuator in the full open (counter clockwise) position.
2. Install the potentiometer next to the indicator shaft where two threaded holes are provided for installation.
3. Align the raised green rib on pot gear with the center line of the indicator shaft.
4. Push the assembly towards the cam to mesh the gears, then tighten the mounting screws.
5. Rotate the actuator handwheel so that the red cam lobe is facing the body of the potentiometer. Make sure that the cam is not touching the potentiometer assembly. Readjust the assembly position if necessary.
6. Cut the terminal marker to fit the 4-pole terminal strip.
7. Mount the 4-pole terminal strip and marker on the switch plate.
8. Wire the potentiometer to the terminal strip using the new wiring diagram.
9. Adhere the new wiring diagram sticker to the inside of the cover.

NOTE:

- Factory will need wiring diagram drawing number and model of the existing unit if it is to be retrofit with a potentiometer. New wiring diagram will be provided based upon this information.

Appendix A

Basic Tools

Common To All Units		
Terminal connections, cam adjustment	Screwdriver, ¼" [6 mm] flat tip blade	
All switches, terminal strip, torque switch plate	Screwdriver, No. 1 Phillips	
Switch plate screws, capacitor	Screwdriver, No. 2 Phillips	
Actuator Size 003, 006		
Mounting nuts	Wrench, ½"	Wrench, M8
Cover captivated capscrews	Hex key, ¼"	Hex Key, M8
Travel stop adjusting bolts and jam nuts	Wrench, ⅞"	Wrench, M6
Motor mount socket flat head capscrew	Hex key, ⅜"	
Motor mount socket head capscrew	Hex key, ⅝"	
Conduit Entry Plug (½" NPT)	Hex key, ⅜"	Hex Key, M20
Actuator Size 008, 012, 020		
Mounting nuts (small pattern)	Wrench, ½"	Wrench, M8
Mounting nuts (large pattern)	Wrench, ¾"	Wrench, M12
Cover captivated capscrews	Hex key, ⅝"	Hex Key, M10
Travel stop adjusting bolts and jam nuts	Wrench, ⅞"	Wrench, M10
Motor mount socket head capscrew	Hex key, ⅜"	
Conduit Entry Plug (¾" NPT)	Hex key, ⅝"	Hex Key, M25
Actuator Size 030, 050, 065		
Mounting nuts (small pattern)	Wrench, ¾"	Wrench, M12
Mounting nuts (large pattern)	Wrench, 1 ⅛"	Wrench, M20
Cover captivated capscrews	Hex key, ⅝"	Hex Key, M20
Travel stop adjusting bolts and jam nuts	Wrench, ¾"	Wrench, M12
Motor mount socket head shoulder bolt	Hex key, ⅜"	Hex Key, M12
Motor mount socket head capscrews	Hex key, ⅝"	
Conduit Entry Plug (¾" NPT)	Hex key, ⅝"	Hex Key, M25
Actuator Size 130, 180		
Mounting nuts (small pattern)	Wrench, ¾"	Wrench, M12
Mounting nuts (large pattern)	Wrench, 1 ⅛"	Wrench, M20
Cover captivated capscrews	Hex key, ⅝"	Hex Key, M12
Travel stop adjusting bolts	Wrench, ⅞"	Wrench, M25
Motor mount socket head shoulder bolt	Hex key, ⅜"	
Motor mount socket head capscrews	Hex key, ⅝"	
Conduit Entry Plug (¾" NPT)	Hex key, ⅝"	Hex Key, M25

Appendix B

Actuator Troubleshooting Chart

Problem	Possible Cause	Solutions
Actuator does not operate	Override is engaged	Push handwheel in all the way
	Wiring is incorrect	Check wiring and power supply
	Actuator motor has reached its thermal shutdown temperature	Allow time to cool
Actuator operates in reverse directions	Field wiring is reversed	Rewire field wiring
Actuator does not fully close valve (or open valve)	Limit switches are depressed	Readjust travel limit switches
	Mechanical travel stop is stopping actuator	Adjust mechanical travel stops
	Valve torque requirement is higher than actuator output	Manually override out of seat, try angle seating or larger actuator
	Optional torque switches are activating	Valve torque exceeds actuator torque rating - consult factory
	Voltage power supply is low	Check power source.
Engaging override handwheel does not shut off motor	Override pin is corroded or damaged	Clean and check for smooth operation of the override switch pin
	Override switch is damaged	Replace switch
Disengaging override hand-wheel does not restart motor	Not completely disengaged	Push handwheel in as far as possible (no yellow showing)
	Override pin is damaged or and does not activate switch	Replace override pin
	Incorrect wiring of override switch	Check wiring
Motor runs but worm and gear segment do not	Worm gear segment is not meshing with worm	Remove switch plate and inspect, adjust travel stops to prevent gear disengaging
	Pin/Key on Worm/Motor drive gear sheared	Replace Pin/Key on drive gear
Corrosion inside unit	Condensation forming	Test heater wiring, should have constant power
	Water leaking in	Check all seals and possible water entry through conduit

Series 70 – Size 003, 006 – Electric Actuator Exploded View

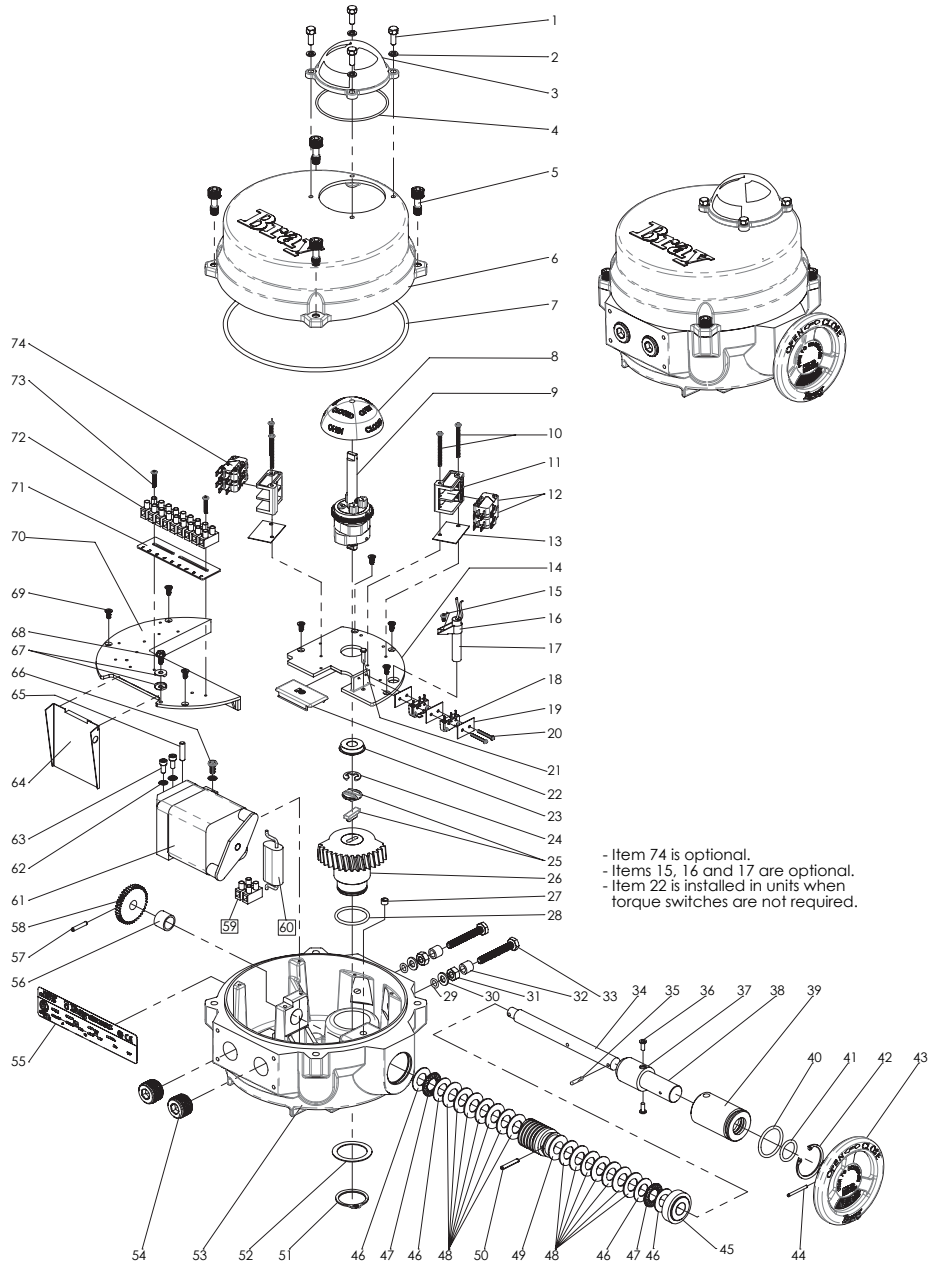

- Item 74 is optional.
- Items 15, 16 and 17 are optional.
- Item 22 is installed in units when torque switches are not required.

Item No.	Description
1	Indicator Cover Screws
2	Lockwasher
3	Position Indicator Cover
4	O-Ring
5	Cover Fastening Screws
6	Cover
7	O-Ring
8	Position Indicator
9	Cam Assembly
10	Limit Switch Screw
11	Limit Switch Bracket
12	Main Open/Closed Limit Switches
13	Limit Switch Insulator
14	Switch Plate, Fixed
15	Heater Bracket Screw
16	Heater Mounting Bracket
17	Heater
18	Override Switch
19	Override Switch Insulator
20	Override Switch Screw
21	Override Switch Trigger Pin
22	Torque Switch Cover
23	Switch Plate Ball Bearing
24	Retaining Ring
25	Coupler
26	Worm Wheel
27	Spring Pin
28	O-Ring
29	O-Ring
30	Nylon Flat Washer
31	Travel Stop Nut
32	Travel Stop Spacer
33	Travel Stop Bolt
34	Worm Shaft
35	Override Drive Pin
36	Spring Plunger
37	Manual Override Shaft Hub

Item No.	Description
38	Manual Override Shaft Stub
39	Manual Override Sleeve
40	O-Ring
41	O-Ring
42	Retaining Ring
43	Handwheel
44	Spring Pin
45	Manual Override Bushing
46	Thrust Washer
47	Thrust Roller Bearing
48	Disc Spring
49	Worm
50	Spring Pin
51	Retaining Ring
52	Thrust Washer
53	Base
54	Conduit Plug
55	Name Tag
56	Bushing
57	Drive Gear Pin
58	Drive Gear
59	Terminal Strip
60	Capacitor
61	Gearmotor
62	Lock Washer
63	Motor Cap Screw
64	Wire Entry Guard
65	Dowel Pin
66	Motor Screw
67	Ground Terminal Washer
68	Ground Terminal Screw
69	Switch Plate Mounting Screw
70	Removable Switch Plate
71	Terminal Strip Marker
72	Terminal Strip
73	Terminal Block Screw
74	Aux Open/Closed Limit Switches

Series 70 – Size 008, 012, 020 – Electric Actuator Exploded View

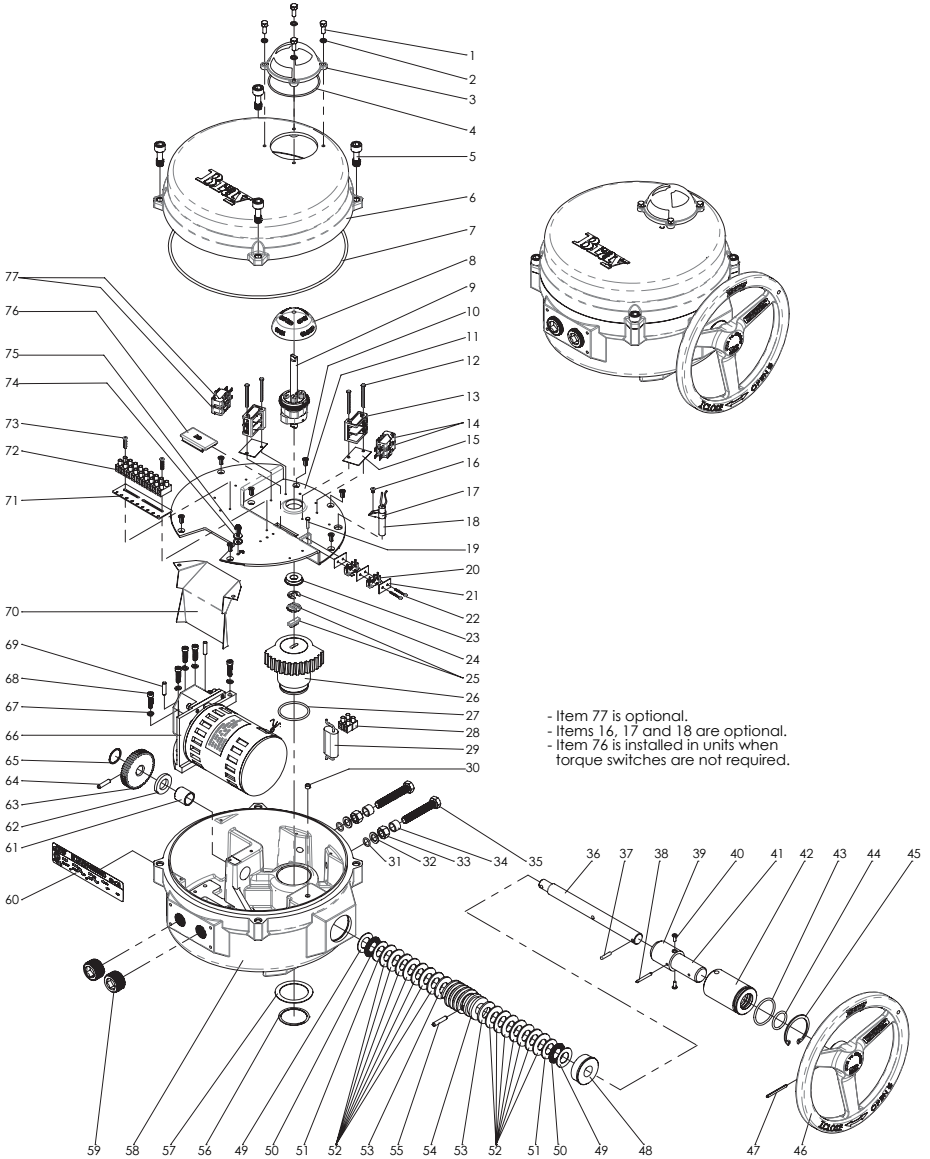

Item No.	Description
1	Indicator Cover Screws
2	Lockwasher
3	Position Indicator Cover
4	O-Ring
5	Cover Fastening Screw
6	Cover
7	O-Ring
8	Position Indicator
9	Cam Assembly
10	Switch Plate Mounting Screw
11	Switch Plate
12	Limit Switch Screw
13	Limit Switch Bracket
14	Main Open/Closed Limit Switches
15	Limit Switch Insulator
16	Heater Bracket Screw
17	Heater Mounting Bracket
18	Heater
19	Override Switch Trigger Pin
20	Override Switch
21	Override Switch Insulator
22	Override Switch Screw
23	Switch Plate Ball Bearing
24	Retaining Ring
25	Coupler
26	Worm Wheel
27	O-Ring
28	Terminal Strip
29	Capacitor
30	Spring Pin
31	O-Ring
32	Nylon Flat Washer
33	Travel Stop Nut
34	Travel Stop Spacer
35	Travel Stop Bolt
36	Worm Shaft
37	Override Drive Pin
38	Spring Pin

Item No.	Description
39	Manual Override Shaft Hub
40	Spring Plunger
41	Manual Override Shaft Stub
42	Manual Override Sleeve
43	O-Ring
44	O-Ring
45	Retaining Ring
46	Handwheel
47	Spring Pin
48	Manual Override Bushing
49	Thrust Washer
50	Thrust Roller Bearing
51	Thrust Washer
52	Disc Spring
53	Disc Spring
54	Worm
55	Spring Pin
56	Retaining Ring
57	Thrust Washer
58	Base
59	Conduit Plug
60	Name Tag
61	Bushing
62	Gear Spacer
63	Drive Gear
64	Spring Pin
65	Retaining Ring
66	Gearmotor
67	Lock Washer
68	Motor Cap Screw
69	Dowel Pin
70	Wire Entry Guard
71	Terminal Strip Marker
72	Terminal Strip
73	Terminal Block Screw
74	Ground Terminal Washer
75	Ground Terminal Screw
76	Torque Switch Cover
77	Aux Open/Closed Limit Switches

Series 70 – Size 030, 050, 065 – Electric Actuator Exploded View

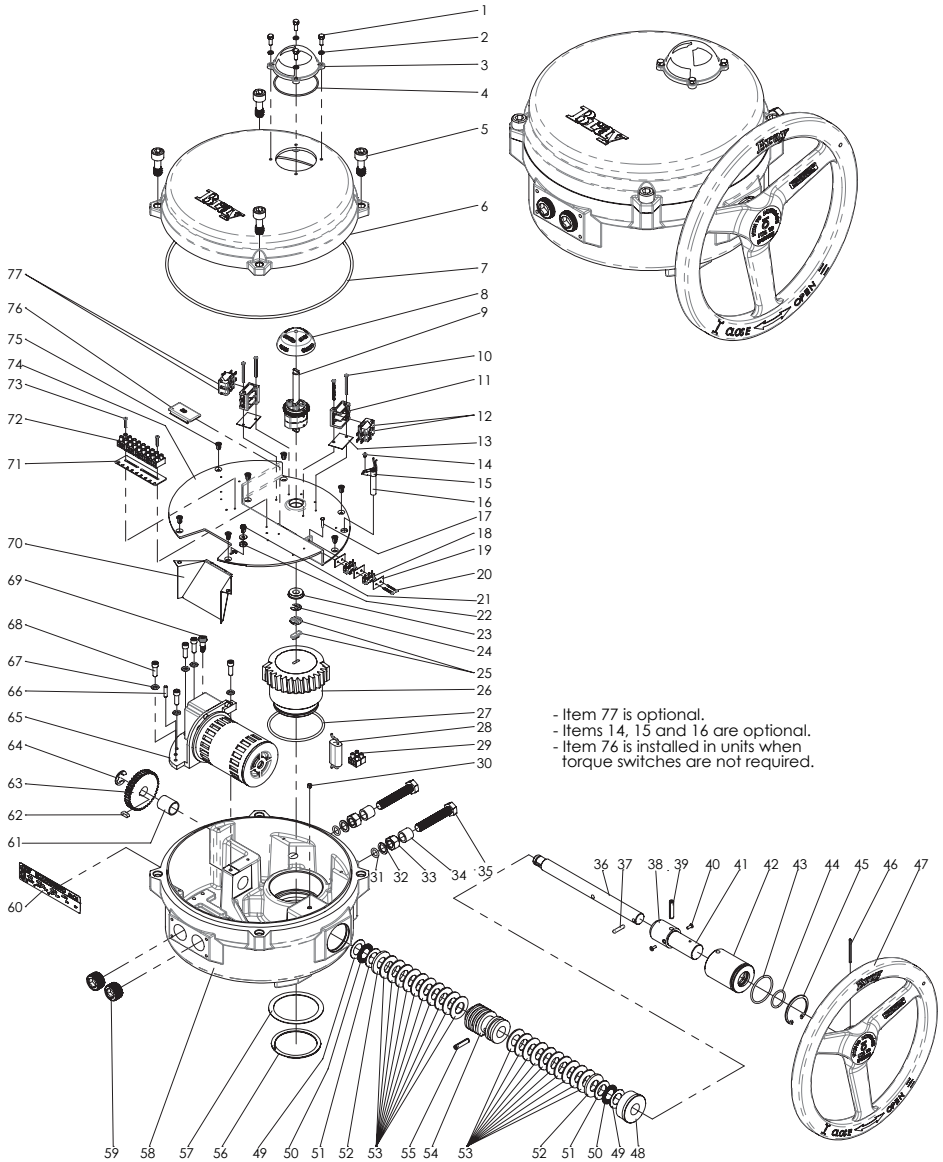

Item No.	Description
1	Indicator Cover Screws
2	Lockwasher
3	Position Indicator Cover
4	O-Ring
5	Cover Fastening Screw
6	Cover
7	O-Ring
8	Position Indicator
9	Cam Assembly
10	Limit Switch Screw
11	Limit Switch Bracket
12	Main Open/Closed Limit Switches
13	Limit Switch Insulator
14	Heater Bracket Screw
15	Heater Mounting Bracket
16	Heater
17	Override Switch Trigger Pin
18	Override Switch
19	Override Switch Insulator
20	Override Switch Screw
21	Ground Terminal Screw
22	Ground Terminal Washer
23	Switch Plate Ball Bearing
24	Retaining Ring
25	Coupler
26	Worm Wheel
27	O-Ring
28	Capacitor
29	Terminal Strip
30	Spring Pin
31	O-Ring
32	Nylon Flat Washer
33	Travel Stop Nut
34	Travel Stop Spacer
35	Travel Stop Bolt
36	Worm Shaft
37	Override Drive Pin
38	Manual Override Shaft Hub

Item No.	Description
39	Spring Pin
40	Spring Plunger
41	Manual Override Shaft
42	Manual Override Sleeve
43	O-Ring
44	O-Ring
45	Retaining Ring
46	Spring Pin
47	Handwheel
48	Manual Override Bushing
49	Thrust Washer
50	Thrust Roller Bearing
51	Thrust Washer
52	Spherical Washer
53	Disc Spring
54	Worm
55	Spring Pin
56	Retaining Ring
57	Thrust Washer
58	Base
59	Conduit Plug
60	Name Tag
61	Bushing
62	Drive Gear Key
63	Drive Gear
64	Retaining Ring
65	Gear Motor
66	Dowel Pin
67	Lock Washer
68	Motor Cap Screw
69	Motor Shoulder Screw
70	Wire Entry Guard
71	Terminal Strip Marker
72	Terminal Strip
73	Terminal Block Screw
74	Switch Plate
75	Switch Plate Mounting Screw
76	Torque Switch Cover
77	Aux Open/Closed Limit Switches

Series 70 – Size 130, 180 – Electric Actuator Exploded View

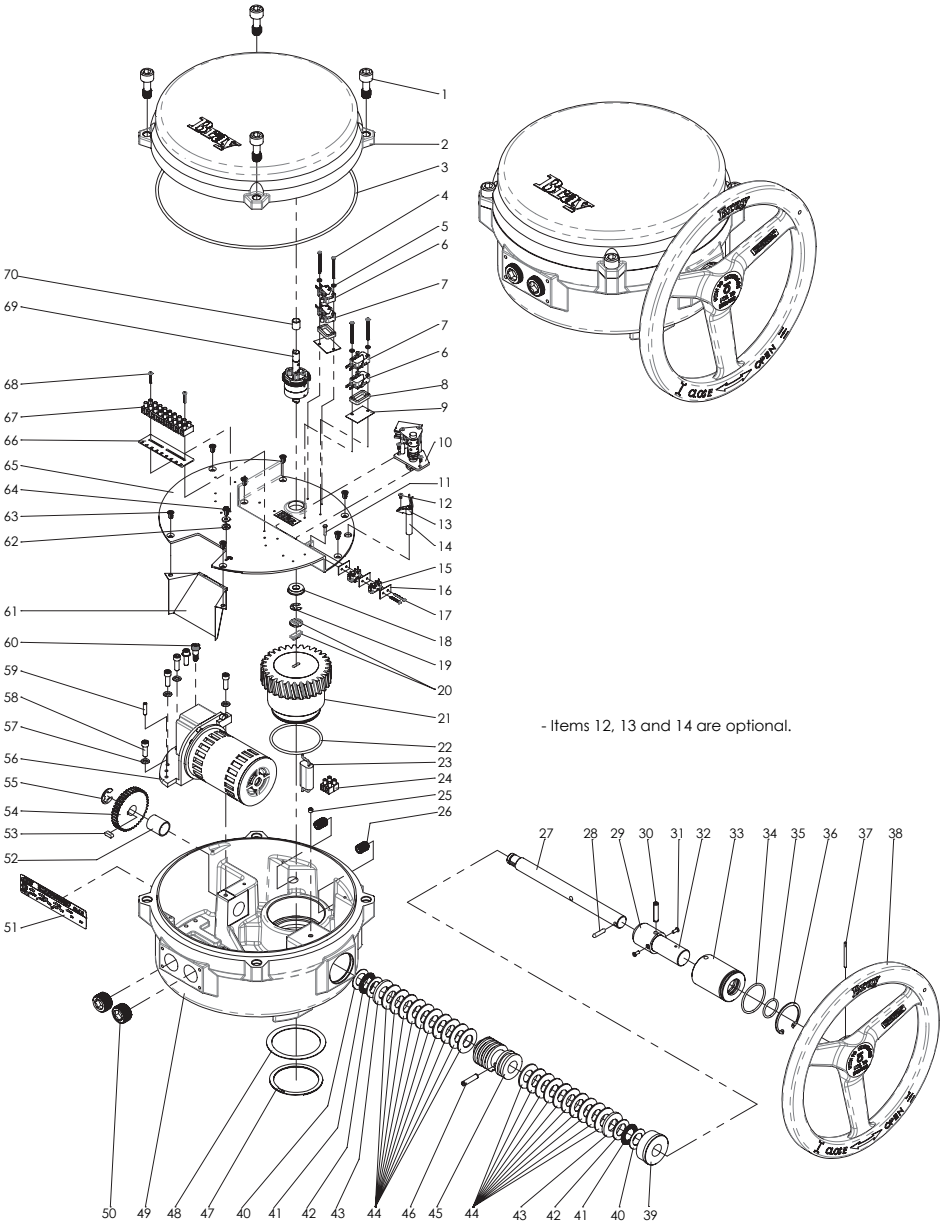

Item No.	Description
1	Cover Fastening Screw
2	Cover
3	O-Ring
4	Limit Switch Screw
5	Flat Insulation Washer
6	Main Open/Closed Limit Switches
7	Aux Open/Closed Limit Switches
8	Switch Spacer
9	Limit Switch Insulator
10	Torque Switch Assembly
11	Override Switch Trigger Pin
12	Heater Bracket Screw
13	Heater Mounting Bracket
14	Heater
15	Override Switch
16	Override Switch Insulator
17	Override Switch Screw
18	Switch Plate Ball Bearing
19	Retaining Ring
20	Coupler
21	Worm Wheel
22	O-Ring
23	Capacitor
24	Terminal Strip
25	Spring Pin
26	Set Screw
27	Worm Shaft
28	Override Drive Pin
29	Manual Override Shaft Hub
30	Spring Pin
31	Spring Plunger
32	Manual Override Shaft Stub
33	Manual Override Sleeve
34	O-Ring
35	O-Ring
36	Retaining Ring

Item No.	Description
37	Spring Pin
38	Handwheel
39	Manual Override Bushing
40	Thrust Washer
41	Thrust Roller Bearing
42	Thrust Washer
43	Spherical Washer
44	Disc Spring
45	Worm
46	Spring Pin
47	Retaining Ring
48	Thrust Washer
49	Base
50	Conduit Plug
51	Name Tag
52	Bushing
53	Drive Gear Key
54	Drive Gear
55	Retaining Ring
56	Gear Motor
57	Lock Washer
58	Motor Cap Screw
59	Dowel Pin
60	Motor Shoulder Screw
61	Wire Entry Guard
62	Ground Terminal Washer
63	Switch Plate Mounting Screw
64	Ground Terminal Screw
65	Switch Plate
66	Terminal Strip Marker
67	Terminal Strip
68	Terminal Block Screw
69	Cam Assembly
70	Bushing

Series 70 – Size 130, 180 – 3:1 Gear Box Exploded View

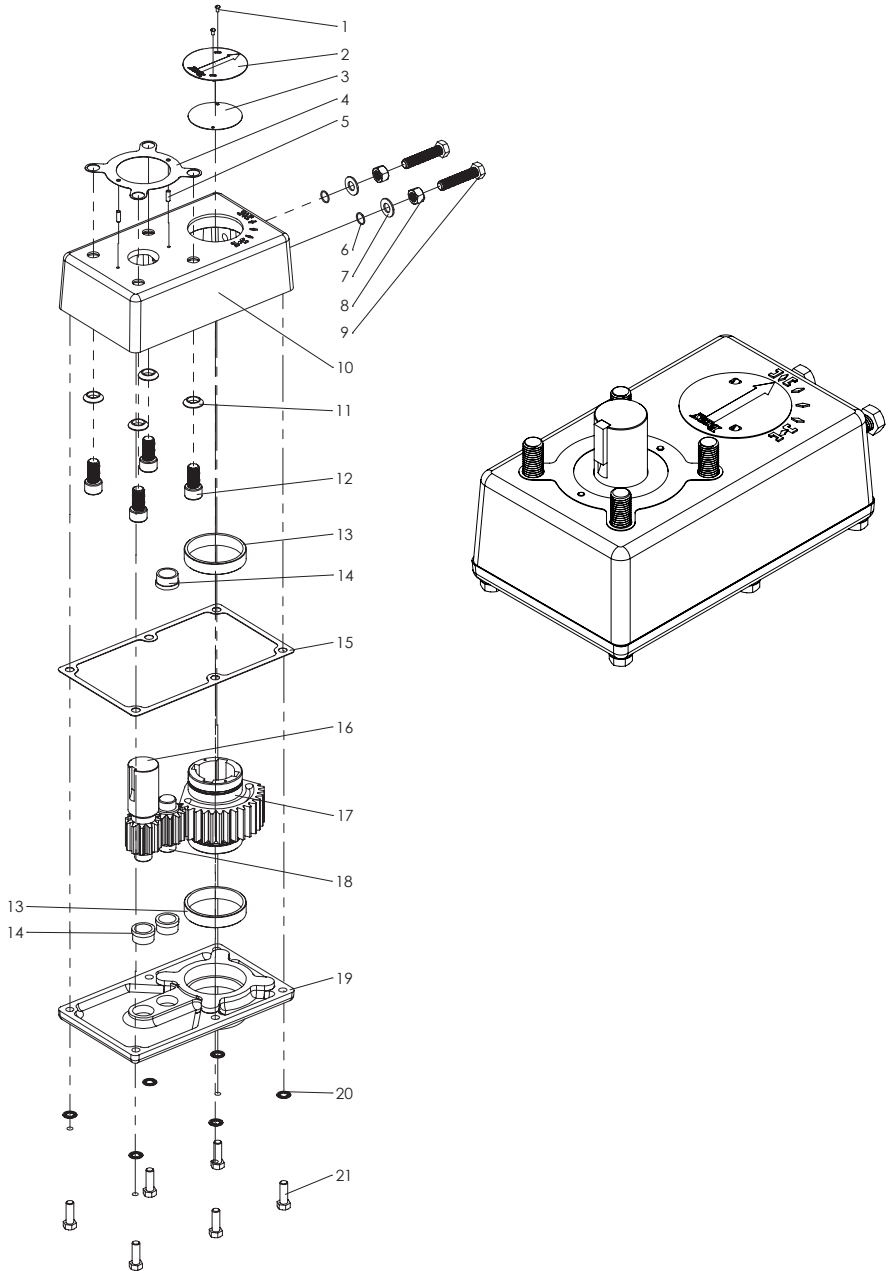

Item No.	Description
1	Fastening Screw
2	Position Indicator Plate
3	Position Indicator Gasket
4	Actuator/Gear Box Gasket
5	Dowel Pin
6	O-Ring
7	Washer, Flat, Nylon
8	Nut, Hex
9	Bolt, Hex Hd
10	Cover
11	Washer, Conical
12	Actuator/Gear Box Fastening Screw
13	Output Gear Bearing
14	Idler/Input Gear Bearing
15	Cover Gasket
16	Input Gear
17	Output Gear
18	Idler Gear
19	Cover
20	Lock Washer
21	Base Fastening Screw



THE HIGH PERFORMANCE COMPANY

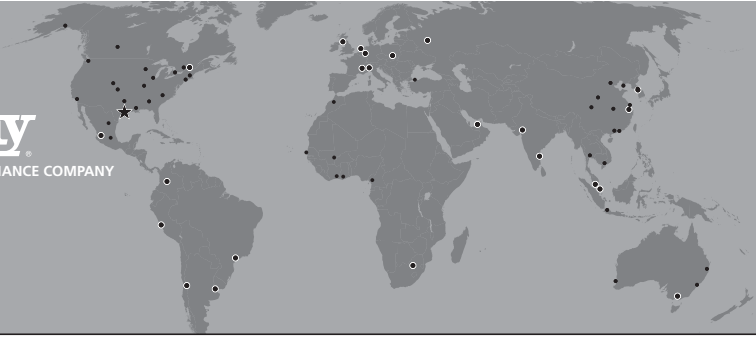

BRAY INTERNATIONAL PRIMARY SALES AND SERVICE LOCATIONS

USA Houston, Texas	CHINA Hangzhou, Zhejiang	MEXICO Zapopan, Jalisco	RUSSIA Moscow
AFRICA Johannesburg	COLOMBIA Bogotá	MIDDLE EAST Dubai	SINGAPORE Ubi Techpark
BENELUX Heerhugowaard	FRANCE Voiron	PACIFIC Melbourne, Australia	SOUTH KOREA Seoul
BRAZIL Paulinia, Sao Paulo	GERMANY Krefeld	PERU Lima	SOUTHEAST ASIA Malaysia
CANADA Montreal	INDIA Vadodara	POLAND Oświęcim	UNITED KINGDOM Glasgow
CHILE Santiago	ITALY Milano		

FLOW-TEK

USA Houston, Texas
BRAZIL Paulinia, Sao Paulo
CHINA Hangzhou, Zhejiang

RITE CORPORATION

CANADA Montreal

VALVTRONIC

ARGENTINA Buenos Aires

AMRESIST

USA Houston, Texas

BRAY/VAAS

INDIA Chennai

KUGELHAHN MÜLLER

GERMANY Krefeld

HEADQUARTERS

Bray International, Inc.

13333 Westland East Blvd.

Houston, Texas 77041

Tel: 281.894.5454

bray.com

All statements, technical information, and recommendations in this bulletin are for general use only. Consult Bray representatives or factory for the specific requirements and material selection for your intended application. The right to change or modify product design or product without prior notice is reserved. Patents issued and applied for worldwide.

Bray® is a registered trademark of BRAY INTERNATIONAL, Inc.

© 2017 Bray International. All rights reserved.

IOM-70 – 01_24_2018