

**INSTALLATION, OPERATION and MAINTENANCE
MANUAL**

**High Pressure
Temperature Control Steam Trap
MODEL: TB 71 / TB 81**



MIYAWAKI INC.

Osaka, Japan

SAFETY INSTRUCTION

Prior to using the models TB 71 / TB 81, read this manual thoroughly to understand the correct handling and operating procedure.

The manual should be used by experienced personnel as a guide to the installation and maintenance of the Steam Traps.

We ask you to contact MIYAWAKI or its local representative if further information is required.

1. Dimensions and Technical Specification

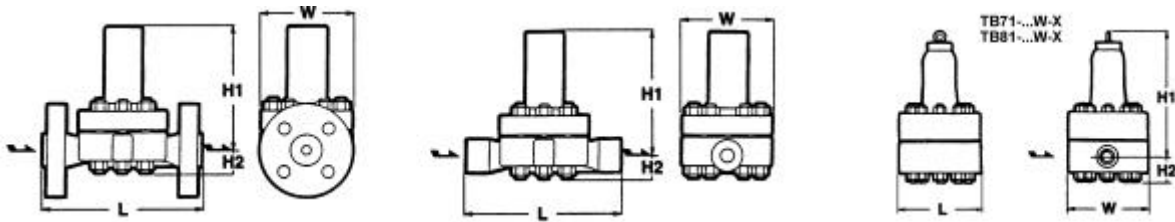

Model	Connection	Size (inch)	Max. Oper. Pressure Mpa (psig)	Max. Oper. Temp. °C (°F)	Adjust. T emp. °C (°F)	Dimensions mm (inch)				Body Mater.	Weight kg (lb)	
						L	H ₁	H ₂	W			
TB71-80W	Socket Weld ANSI, JIS, DIN	1/2"- 1"	7,8 (1130)	470 (878)	100-260 (212-500)	250 (9.8)	201 (7.9)	36 (1.4)	145 (5.7)	Cast Steel WC 6	15 (33.0)	
TB71-105W			10,3 (1500)		100-280 (212-536)						15 (33.0)	
TB81-150W			14,7 (2130)		100-300 (212-572)	400 (15.7)	268 (10.5)	45 (1.8)	180 (7.1)	Forged Steel A 182 F 12	31 (68.2)	
TB81-150W-X			14,7 (2130)		392°F/ 545psig						173 (6.8)	29,5 (65.0)
TB81-200W			19,6 (2840)		100-320 (212-608)						31 (68.2)	
TB71-80F	Flanged ANSI, JIS, DIN	1/2"- 1"	7,8 (1130)	470 (878)	100-260 (212-500)	260 (10.2)	201 (7.9)	36 (1.4)	145 (5.7)	Cast Steel WC 6	20 (44.0)	
TB71-105F			10,3 (1500)		100-280 (212-536)						20 (44.0)	
TB81-150F			14,7 (2130)		100-300 (212-572)	400 (15.7)	268 (10.5)	45 (1.8)	180 (7.1)	Forged Steel A 182 F 12	38 (83.6)	
TB81-200F			19,6 (2840)		100-320 (212-608)						38 (83.6)	

2. Installation

CAUTION	Before installing the trap, always blow down the piping that leads to the trap's inlet.
----------------	---

CAUTION	The Temperature Control Trap TB71/TB81 can be installed either horizontally, or vertically.
----------------	---

- A. Install the trap according to the direction of the arrow on the body.
- B. Install the trap so that the condensate will flow naturally into the trap.
- C. Don't insulate the trap.
- D. The trap has an integral strainer screen. But if the steam/condensate are very dirty install additionally a strainer or a dirt pocket before the trap.
- E. It is recommended to design the piping as shown in the drawings below. Install the trap at the bypass side.
- G. In case of draining steam mains use branch lines of a size of $\frac{3}{4}$ " or 1". Don't insulate the pipe before the trap.
- F. Install the trap for easy maintenance. About 200 mm space is necessary for disassembling the cover.

Traps shall be socketwelded using a Qualified Weld Procedure which does not require Post-Weld Heat Treatment. Pre-Heat requirements shall be in accordance with ANSI B 31.1. or B 31.3. as applicable. These codes exempt such socketwelds from being post weld heat treated.

In all cases care shall be taken to avoid excessive heat input to the trap. In no case shall the traps be placed in a heat treating oven.

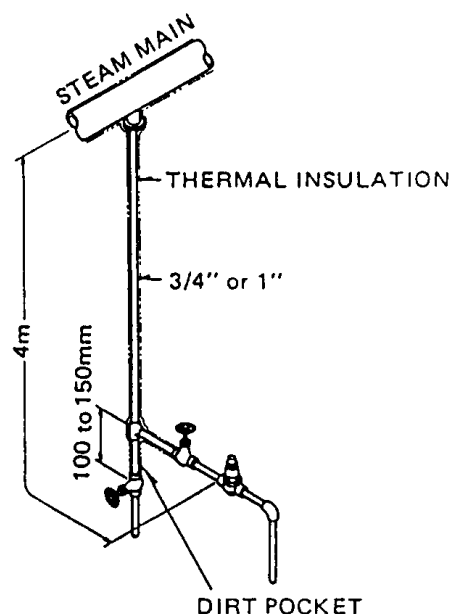
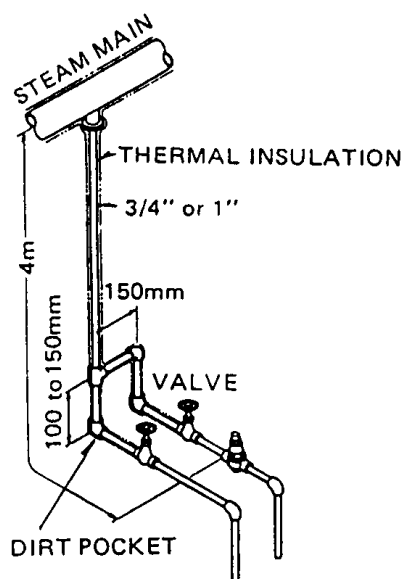

3. Trouble-shooting

The Steam trap should be checked for proper operation at least once a year.

The Temperature Control steam trap TB71/TB81 discharges the condensate usually continuously. If the trap is setted at a temperature near to the saturation temperature and the condensate load is very low the trap may discharge intermittently.

Problem	Reason
The trap is not discharging condensate.	A. At time of installation the inlet and outlet of the trap had been confused. B. The operating pressure is higher than the maximum allowable operating pressure of the trap. C. The strainer is plugged. D. The valve seat is plugged. C. The spring (26) is damaged.
The trap is blowing through steam.	A. The setting temperature is not correct (Considering the operating pressure, the temperature is setted too high. The valve cannot close). Adjust the trap again. B. Scale is lodged between the valve and the seat. C. The valve or the valve seat are worn or damaged. D. The bimetal unit is damaged.
The trap is leaking steam.	A. The valve (6) and/or the valve seat (5) are worn.

4. Adjustment of the Discharging Temperature

The temperature adjustment is required initially and at times when the operating conditions have changed.

Usually the trap had been adjusted at the factory according to the operating conditions of the customer and must not be readjusted.

To readjust the trap perform the following steps:

- A. Be sure to close the valves in both supply and discharge lines, reduce the pressure inside the trap to atmospheric pressure, and allow the trap to cool before adjusting it.
- B. Remove the Cover Bolts and nuts (17,18) and remove the Cover (2).
- C. Loosen the Adjust Nut (22).
- D. Turn the Adjust Bolt (23) clockwise until it stops at the zero point.
- E. Check the number of turns you need for setting the appropriate temperature by using the temperature stroke chart.

- F. Turn the Adjust Bolt counter-clockwise to the number of turns which are required.
- G. Fix the Adjust Bolt with the Adjust Nut.
- H. Put the Cover on the Body, install and tighten the Cover Bolts.

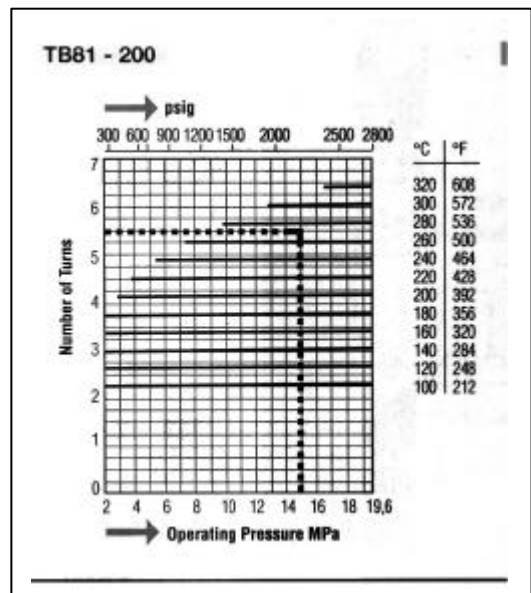
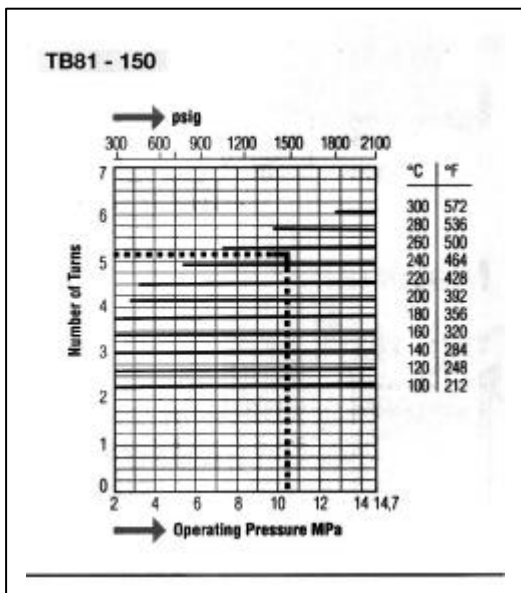
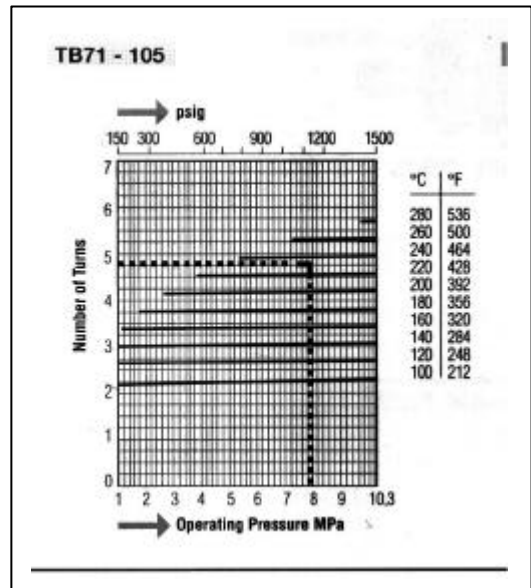
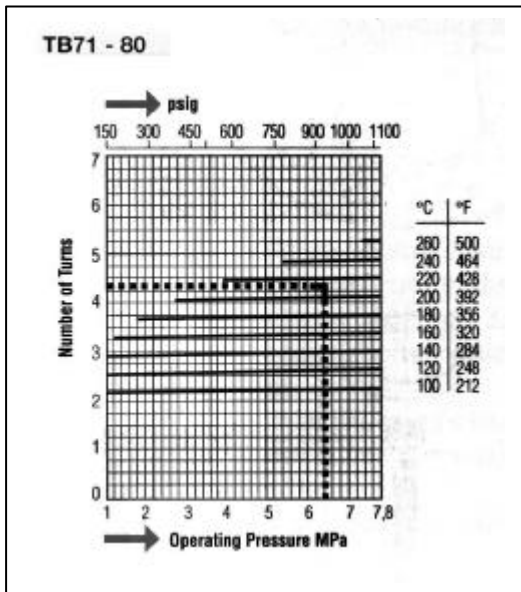

The dashed line shows the standard factory setting.

5. Maintenance, Disassembling and Assembling

WARNING	Before dsassembling a steam trap be sure to close the valves in both supply and discharge lines, reduce the pressure inside the trap to atmospheric pressure, and allow the trap to cool before opening it.
----------------	---

For cleaning purposes or for changing parts perform the following steps:

- A. Remove the Cover Bolts and Nuts (17,18). Take off the Cover (2).
- B. Loosen the Guide Tube (28) with a Pipe wrench. The screen (15) , the Adjust Nut (22), the Adjust Bolt (23) and the Adjust Bush (24) can be taken off together.
- C. Now you can remove the Valve Holder (27) together with the Bimetal Unit (8,21), the Valve (6), and the Bush (25).
- D. Now you can take out the Spring (26).
- E. For checking the valve seat, remove the Seat Bush (3) and the Valve Seat (5) with a wrench.
- F. Clean and inspect all parts. Replace any that are worn or damaged.
Assemble in the opposite way as disassembling.

Especially thoroughly check the Valve (6) and the Valve Seat (5).

When there will be the necessity to replace the Valve (6) and/or the Valve Seat (5) always replace both together as they are lapped together in the factory.

CAUTION	Tighten the Cover Bolts and Nuts (17,18) evenly crosswise.
----------------	--

Wrench Sizes and Torques

Parts Number	Parts Name	Wrench Size	Torque
3	Seat Bush	41 mm	1,400 kgf-cm
5	Valve Seat	23 mm	800 kgf-cm
18	Cover Nut	24 mm – TB 71 27 mm – TB 81-150 32 mm – TB 81-200	900 kgf-cm – TB 71 1,500 kgf-cm – TB 81-150 2,400 kgf-cm – TB 81-200
22	Adjust Nut	17 mm	-
24	Adjust Bush	37 mm	-

5. Details and Spare Parts List

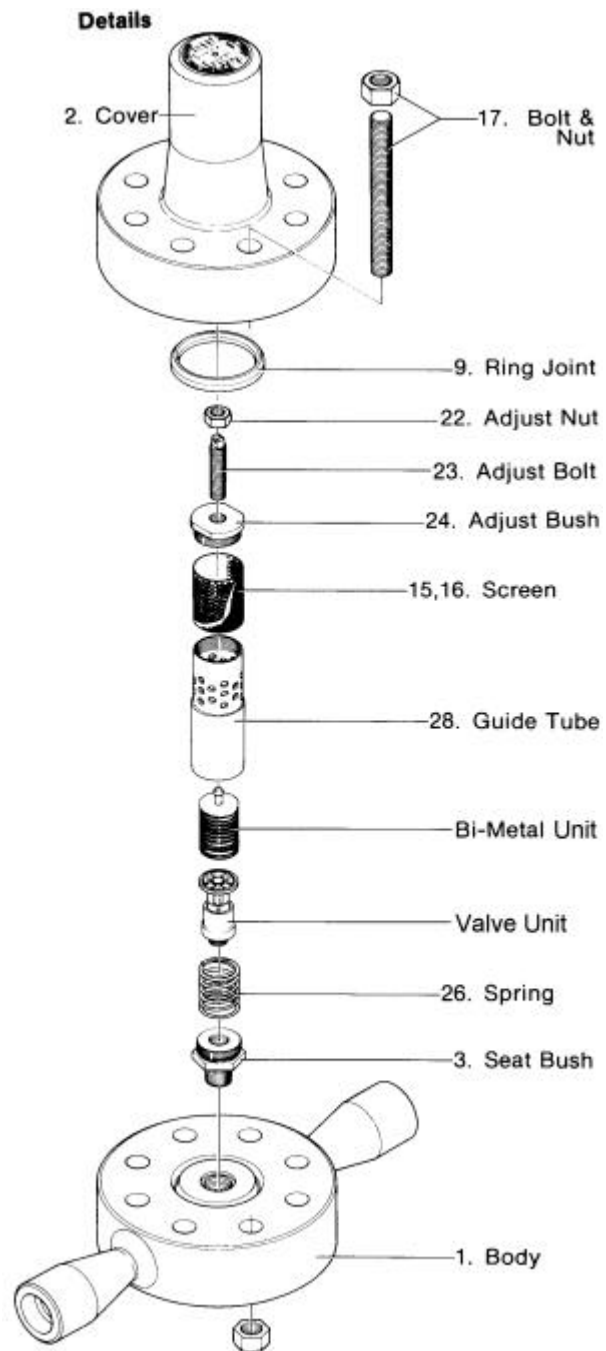

SPARE PARTS LIST

No.	Parts / Unit Name
5, 6, 25, 27, 30, 31	Valve Unit
4, 7, 8, 21	Bimetal Unit
9	Ring Joint
15,16	Screen