

# TBC2

## Table of Contents

1.Specifications and markings.....	GB-01
2.Construction details.....	GB-02
3.Installation.....	GB-02
4.Setting the temperature .....	GB-03
5.Stroke table .....	GB-04
6.Maintenance .....	GB-04
7.Troubleshooting .....	GB-07
8.Warranty.....	GB-08



ISO9001  
JMI-0205  
Head office & Factories



ISO14001  
JQA-EM1403  
Head office & Factories

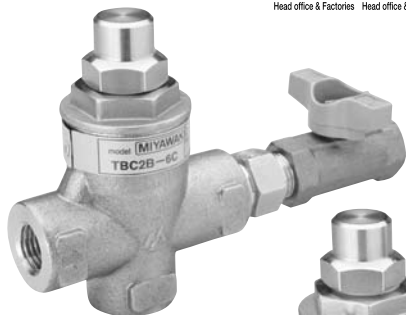

**TBC2B-6C:**  
Angled type with  
a blow valve

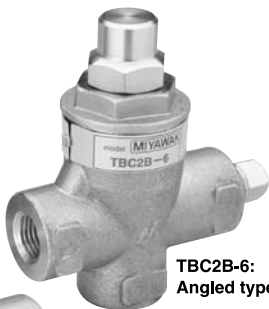

**TBC2B-6:**  
Angled type



**TBC2-6:**  
Straight type

The TBC2 is a bimetal temperature control steam trap that has superior durability and essentially doesn't allow steam to leak. In order to get maximum benefit from this product, be sure to read this manual before installation.

The following warnings and cautions are shown at appropriate places in this manual.



Failure to observe this type of precaution may lead to serious injury or death.



Failure to follow this type of precaution can lead to injury or damage to equipment and property.

## 1 Specifications and markings



Be sure not to use this product at higher pressures than the specified maximum allowable pressure (PMA) or at temperatures higher than the specified maximum allowable temperature (TMA).

The following items are displayed on the nameplate or on the side of the body. Check each item to avoid misuse of the product.

- (1) Maximum allowable pressure (PMA): 2.1 MPa(305psig)  
{However, for the TBC2B-6C the PMA is 0.98MPa(142psig)}
- (2) Maximum allowable temperature (TMA): 220°C(428°F)  
{However, for the TBC2B-6C the TMA is 183°C(361°F)}
- (3) Maximum operating pressure (PMO): 0.6 MPa(87psig)
- (4) Maximum operating temperature (TMO): 220°C(428°F)  
{However, for the TBC2B-6C the TMO is 183°C(361°F)}
- (5) Size: 8 mm(1/4"), 10mm(3/8")
- (6) Set temperature: The temperature at which the condensate will be discharged from the steam trap.
- (7) Year of production: The two leftmost digits in the five-digit 'S No.' on the nameplate are the last two digits of the year of production.
- (8) Flow direction: Shown by an arrow.
- (9) Body material: SCS13A.

\* Refer to the leaflet for details about dimensions and other specifications

## 2 Construction details

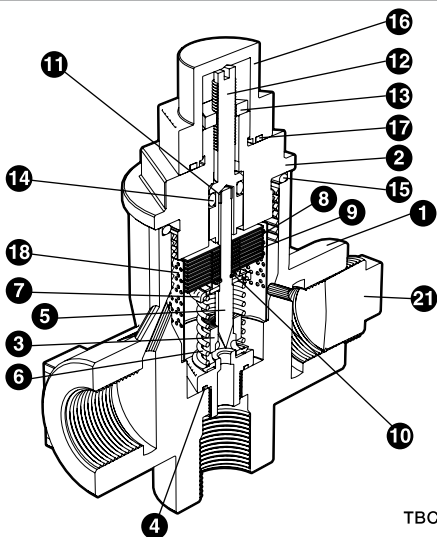

- 1 Body
- 2 Cover
- 3 Valve Seat
- 4 Gasket
- 5 Valve
- 6 Spring
- 7 Spring Plate
- 8 Bi-Metal
- 9 Washer
- 10 E-Ring
- 11 Stopper
- 12 Adjust Bolt
- 13 Adjust Nut
- 14 O-Ring
- 15 O-Ring
- 16 Cap
- 17 Gasket
- 18 Screen
- 21 Plug

TBC2B

## 3 Installation



- Pay very careful attention when working in hazardous environments such as this. There is a risk of explosion and the possibility of dangerous gases leaking. Always check whether the pipeline contains flammable, high pressure or high temperature materials before starting to work.

\* Make sure that isolation valves are installed on both the upstream and downstream lines.



- Before installing the product, open both isolation valves and the bypass valve, if one exists, to blow out any debris or dirt inside the pipeline. After blowing out the line, before starting to work, close the isolation valves and allow time for the temperature to drop to a safe working temperature.

\* When installing the product, be sure to leave clearance for maintaining it.

- Remove the dustproof seals covering both connections.
- Check the flow direction indicated on the side of the body.
- The TBC2 can be used for both horizontal and vertical lines. However, be sure not to install it upside-down in a horizontal line, as it will cause the trap to malfunction. When installing a TBC2 in a horizontal line, be sure to maintain a slight slope to the line, so that any condensate will flow smoothly.
- Open the isolation valve on the upstream line slowly and make sure the product works normally.

## 4 Setting the temperature



**WARNING**

Only set the temperature when the bimetals in the body are flat, before any steam is flowing. Be sure not to set the temperature while the steam is flowing because the steam or condensate may spurt out around the edges in the setting part.

### ○ Set temperature

The set temperature is the temperature at which condensate will be discharged from the temperature control steam trap. It is set to the temperature specified by the customer when shipped. If the customer doesn't specify a temperature, it is always set to 70°C at a pressure of 0.5 MPa, as the factory default setting. The set temperature is also stamped on the nameplate.

### ○ Setting the temperature

- Remove the cap (16).
- Hold the adjusting bolt (12) using a screwdriver, and loosen the adjusting nut (13) using a wrench.
- Screw the adjusting bolt (12) slowly clockwise until stops. This position is the starting point to set the temperature.
- See the stroke table in Section 5 to find the number of turns corresponding to the temperature you want.
- Screw the adjusting bolt (12) counterclockwise the number of turns specified in the table.
- Hold the adjusting bolt (12) using a screwdriver, and then lightly tighten the adjusting nut (13).
- Attach the cap (16).

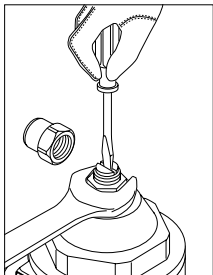

### ○ Precautions for setting the temperature

- Steam trace  
Basically, the set temperature should be the temperature used to control the objects being heated. However, please make sure to consult us if you will use the product in a cold climate.
- Other equipment  
Since the appropriate set temperature depends on the equipment, please consult us.

## 5 Stroke table

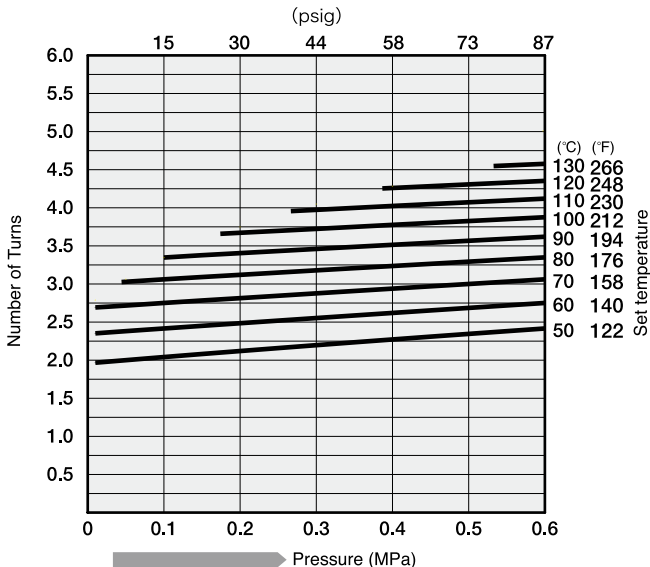

## 6 Maintenance



- When replacing parts, make sure the replacement parts are supplied by Miyawaki.

The performance of steam traps deteriorates gradually over time due to wear, corrosion, or dirt accumulating around the valve seat. To keep steam control systems and equipment working well, periodic maintenance of steam traps is essential.

### ○ Tools for testing steam traps

In order to test steam traps, ultrasonic testers, sound detectors, and thermometers have been used for years. These tools are relatively easy to use and are useful for making rough estimates of the level of deterioration in a defective trap. However, to determine deterioration levels and steam losses quantitatively, special tools for testing steam traps are required.

Dr. Trap and Dr. Trap Jr. are testing equipment that was developed specifically for diagnosing steam traps and analyzing survey results automatically. Use these tools to avoid tiresome jobs on site and save working time.

### ○ Working conditions of a steam trap

Steam trap failures can be classified as either 'Leaking' or 'Plugged'. The level of a steam leak is generally determined by the intensity of the ultrasonic vibration generated in the valve seat inside of a steam trap. Plugging is diagnosed by measuring the surface temperature. As plugging progresses due to a buildup of dirt in the trap, it finally becomes completely plugged. Then the surface temperature will be much lower than the preset temperature.

### ○ Repairs

When a trap fails, it is necessary to clean the internal parts and to replace damaged parts.

Take the failed trap apart following the steps below.

- Loosen the cover (2), and remove the adjustment unit including the cap (16), the adjusting bolt (12), the adjusting nut (13), the O-ring (14), and the cap (17).
- Remove the valve unit and the spring (6) by hand.
- Remove the valve seat (3) using a socket wrench.

After repairing the trap, re-assemble the parts in reverse order, as follows.

- Insert the seat gasket (4), screw the valve seat (3) into the body (1).
- Reinstall the screen (18) in the body (1).
- Reinstall the spring (5) on the valve seat.
- Reinstall the valve unit so that the spring plate (7) on the valve unit fits into the spring (6).
- After placing the cover o-rings (15) in the body (1), screw the cover (2) onto the body (1). Then, reinstall the adjustment unit.

\* The proper torque for the cover (2), valve seat (3), and cap (16) are as shown in the following table.

Parts	Tool	Across the flats	Torque
Cover (2)	Torque wrench	24 mm (0.94 in)	35 N-m (350 kgf-cm) (304 lbf-in)
Valve seat (3)	Torque wrench	12 mm (0.47 in)	12 N-m (120 kgf-cm) (105 lbf-in)
Cap (16)	Torque wrench	19 mm (0.75 in)	25 N-m (250 kgf-cm) (217 lbf-in)
Adjusting nut (12)	Wrench	8 mm (0.31 in)	—————

\* When the adjustment unit is disassembled, after reassembling it set the temperature again, following the steps shown in the Section 4, "Setting the temperature".

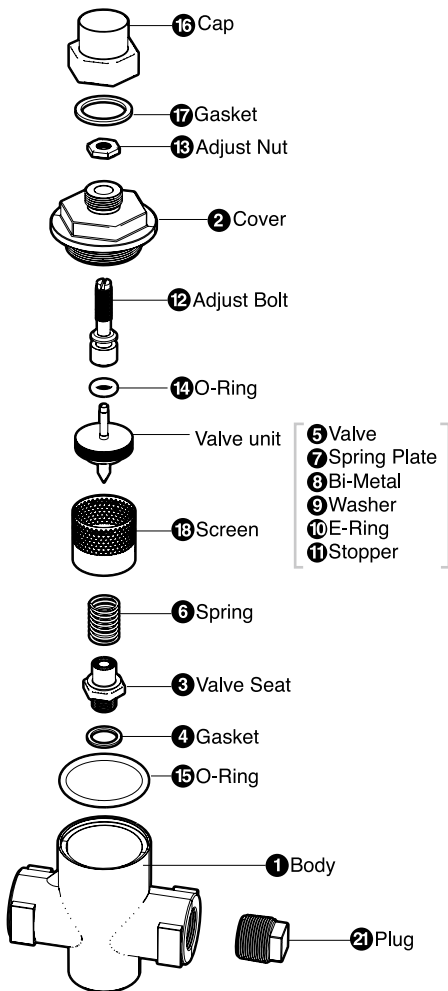

# 7 Troubleshooting

Problem	Possible causes	Solution
<b>Steam leaks or blows through.</b>	Stuck valve or dirt accumulated around the valve (5) or valve seat (3)	Clean the valve (5) and the valve seat (3).
	The valve seat (3) is loose.	Tighten the valve seat (3). *1
	Damage, erosion or corrosion of the valve seat (3) or the valve (5)	Replace the valve unit.
	The seat gasket (4) is damaged.	Replace the seat gasket (4).
	The bimetal (8) is damaged.	Replace the valve unit.
	The adjusting bolt (12) is backed out too far. (Improper set temp.)	Set the temperature again.
	Improper installation direction	Reinstall the product in the correct direction.
<b>Steam leaks from the body.</b>	The cover (2) is loose.	Tighten the cover (2). *2
	The cover O-ring (15) is damaged.	Replace the cover O-ring (15).
	The cap (16) is loose or the gasket (17) is damaged.	Tighten the cap (16)*3 or replace the gasket (17).
<b>Insufficient condensate discharged, or no condensate discharged.</b>	The screen (18) is clogged.	Clean the screen (18).*4
	Dirt has built up on or around the valve seat (3).	Clean the valve seat (3).
	Dirt accumulated in the fluid passage of the body (1)	Clean the body (1).
	The bimetal (8) is damaged.	Replace the valve unit.
	The adjusting bolt (12) is too tight. (Improper set temp.)	Set the temperature again.
	Insufficient condensate capacity	Replace the trap with a larger capacity.

\*1, \*2 and \*3: To find the proper torque, refer to the torque table in Section 6, "Maintenance".

\*4: When the screen (18) is clogged, you must operate the blow valve in the TBC2B-6 and TBC2B-6C to blow the dirt away from the outer section of the screen.



## 8 Warranty

### Warranty period

The warranty period shall last 12 months from the date of product delivery.

### Details of warranty

If the product stops working correctly within the warranty period, we will repair or replace the product free of charge if the cause of the trouble is not one of the following items.

- 1) The precautions described in this manual were not observed.
- 2) User's errors or mistakes such as an inappropriate installation or incorrect handling, or an excessively large impact caused by dropping
- 3) Problems caused by devices or equipment other than ours, or a disallowed use environment
- 4) When a repair or modification has been performed by anyone other than us or people who have authorized to make such repairs
- 5) Intrusion of salt or other substances that promote significant rust or corrosion or problems from fluids that contain the same substances
- 6) Extremely worn packing, gaskets, or other parts
- 7) Attachment or accumulation of foreign objects in the pipe, such as dust and scale
- 8) Problems from fires, natural disasters, or other force majeure which is not our responsibility

### Warranty limitation

The remedy available under the warranty shall not exceed the sales price of the products delivered, for any cause whatsoever.

- お買い上げの製品及びこの取扱説明書内容についてのご質問は下記にお問い合わせください。  
また、この取扱説明書を紛失したり、汚損により読めなくなった場合は、同じく下記にご請求ください。

For any questions about the product that you purchased or about the details in this instruction manual, please contact the following.

If you lose this user's manual or can no longer read it due to stains, please make a request to the following.



---

### **MCSセンター**

〒532-0021 大阪市淀川区田川北2-1-30

TEL.06-6302-5590 FAX.06-6305-4089

<http://japan.miyawaki.net> e-mail:mcs@miyawaki-inc.co.jp

### **INTERNATIONAL SALES DEPT.**

2-1-30, TAGAWAKITA, YODOGAWA-KU, OSAKA 532-0021, JAPAN

TeL : +81-6-63025549 Fax : +81-6-63025595

<http://www.miyawaki.net> e-mail: export@miyawaki-inc.co.jp

