

The Ultimate Critical Service **TRIPLE OFFSET VALVE**

# **Bray** INTERNATIONAL, Inc.

*At Bray, our business is helping our customers with their flow control requirements. Our modular product line of valves, actuators and accessories offer the best compatibility, economy and quality performance in the flow control industry.*

*Through years of field application experience, research and development Bray has designed products that meet or exceed the stringent requirements of today's flow control industry. We have earned a reputation for excellence by creating products of superior value and quality, providing personalized customer service and emphasizing on-time deliveries. Our success has always been the direct result of our fully integrated range of valve, actuator and control products. Rugged and reliable, our products are engineered to provide years of trouble free service.*

*Bray manufacturing facilities are certified to ISO 9001 and EU Directives, assuring product quality, precision manufacturing and internal process integrity.*

*Bray's extensively trained staff is knowledgeable in all aspects of flow control technology and provide personal attention to every customer. To serve you locally, each region maintains a factory certified sales and service network for all Bray International products.*



Bray International Headquarters – Office & USA Manufacturing  
Houston, Texas +281.894.5454

## COMMITTED TO QUALITY

Meeting the expectations and needs of our customers while continually improving the effectiveness of our quality management.





## Assuring The Product You Receive Is The Product You Purchased

Product reliability and performance are directly related to quality and a major concern of any customer who must have the assurance they are receiving products as designed, with a material and quality level that meets or exceeds their requirements.

**Material Verification and Traceability** - Bray's in-house lab is equipped with fully calibrated equipment in accordance with international and NIST requirements for verifying chemical and physical properties of a wide variety of materials. Supplier's Material Test Report (MTR) and Bray's associated test verification are maintained indefinitely for all valve pressure retaining components.

**Positive Material Identification** - Trained operators using certified equipment perform in-house PMI testing to verify material traceability reports and ensure specific materials are utilized for valve assemblies.

**Coordinate Measurement** - Electro-mechanical machines utilize touch probing methodology (and analyze data via regression algorithms to interpret raw input against comparative information) throughout the engineering and manufacturing process verifies the physical geometric characteristics (such as dimensions and tolerances) of a part or assembly against its design intent.

Bray's in-house quality assurance program also utilize test protocols which could include Magnetic Particle (ASTM E709) or Dye/Liquid Penetrant (ASTM E165) inspection to provide state-of-the-art material examination technology/procedures in today's global environment.



Positive Material Identification



A complete listing of approvals & certifications can be found at [www.bray.com](http://www.bray.com).

# TRIPLE OFFSET QUARTER TURN VALVES



Front



Side

**Bray** **TriLok**

A Division of Bray International, Inc.

## BODIES AVAILABLE:

WAFER

LUG

FLANGED

GATE

BUTTWELD

## ASME CLASS & SIZES:

150 3" - 48" (80mm - 1200mm)

300 3" - 48" (80mm - 1200mm)

600 6" - 24" (150mm - 600mm)

900 8" - 24" (200mm - 600mm)

## TEMPERATURE RANGE:

-320°F to 842°F (-196°C to 450°C)

30" ASME 150 Double Flanged Body - Carbon Steel

## REPLACEABLE SEAT/SEAL SYSTEM

Tri Lok Series valves feature independent field replacement of both the seat and the seal ring. Should service conditions change, seat and seal ring materials may be substituted, without replacing the entire valve. Maintenance, downtime and costs are substantially reduced extending the overall service life of the valve.

Tri Lok's non-rubbing metal-to-metal seal delivers zero leakage with a minimal amount of torque and is inherently firesafe. The standard seat and seal ring material is stainless steel with other materials including Stellite® overlays available. The resiliency of the seal ring ensures uniform peripheral sealing with the seat, achieving full shutoff regardless of flow direction. Tri Lok offers a solid metal seal ring for high temperature and severe service applications to ensure bi-directional shut-off throughout the full pressure/temperature range.



## SPLINED DISC/STEM CONNECTION

Tri Lok's internal disc-to-stem connection eliminates external retention components, such as taper pins or keys. Potential issues associated with external connections, such as corrosion or vibration failure, are eliminated. Additionally, these external connections often require machining or grinding for removal. Disassembly of the Tri Lok disc and stem is as simple as sliding the shaft from the disc.

Tri Lok is the only valve in its class with a splined disc/stem connection. The Tri Lok connection allows axial movement of the disc independent of the stem. Therefore, the seal ring and seat remain in position, unaffected by temperature fluctuations and pressure effects on the stem. This design prevents the typical misalignment problems of rigidly attached discs and stems. The splined connection offers maximum strength. Close tolerance engagement between the disc and stem minimizes hysteresis.



# METAL-TO-METAL SEALING PRINCIPLE

Torque Seated ▪ Non-Rubbing Thru Rotation ▪ Resilient Seal Ring



No contact prior to seating



Contact only once seated

## TRIPLE OFFSET GEOMETRY

The stem is offset on both the X (1) and Y (2) axis of the valve's centerline. This produces a cam-like motion. The third offset (3) consists of an inclined conical profile machined into the valve sealing surface. This allows rotary engagement and disengagement of the seat and seal ring without interference. All rubbing between seat and seal ring is thereby eliminated.

Once the seat and seal ring are fully engaged, torque is applied in order to create a bi-directional, zero leak, metal-to-metal seal. For this reason, triple offset valves are often defined as "torque" seated rather than "position" seated as in the case of resilient or high performance products.

Tri Lok's geometry immediately disengages the entire seal ring from the seat upon opening rotation, which eliminates rubbing between these materials.

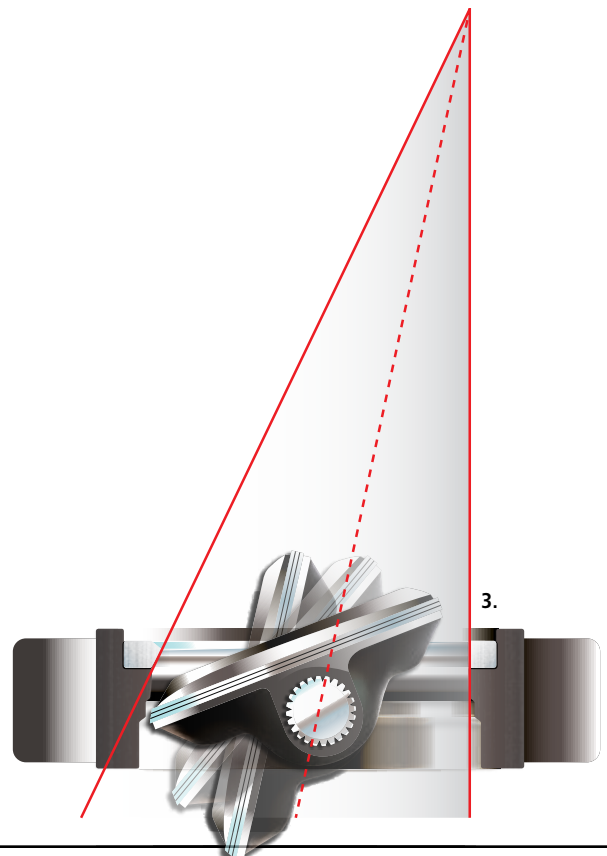
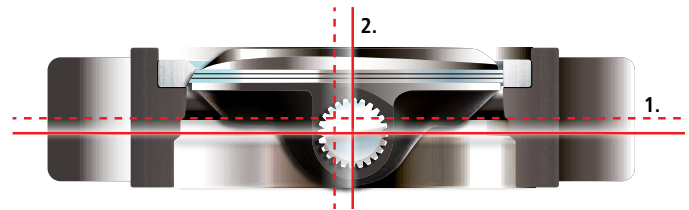

# DESIGN SPECIFICATIONS

Tri Lok Valves Meet The Following Standards / Specifications:

**VALVE DESIGN  
& PRESSURE/TEMPERATURE  
RATINGS:**

ASME B16.34  
ASME VIII  
API 609  
DIN 3840

**FIRE TESTED:**

API 607, 6TH EDITION  
ISO 10497

**CRYOGENIC:**

BS 6364

**FUGITIVE EMISSION  
TESTING:**

TA LUFT  
ISO 15848

**ACTUATOR MOUNTING:**

ISO 5211

**FACE TO FACE DIMENSIONS:**

API 609  
ASME B16.10  
ISO 5752  
EN558-2

**SEAT TESTING:**

API 598  
API 6D  
ISO 5208  
DIN 3230  
BS 6755

**FLANGE DRILLING:**

ASME B16.5  
ASME B16.47  
ISO 7005  
DIN 2501

**VALVE MARKINGS:**

MSS-SP-25  
ASME B16.34

**MANUFACTURING QUALITY:**

ISO 9001  
CE/PED



12" ASME 600 ISO  
Double Flanged Body  
Stainless Steel

Contained in this brochure is an overview of the Tri Lok's primary features.  
For complete technical data please contact the Bray factory or authorized distributor.

---

## BODIES AVAILABLE:

WAFER, LUG, FLANGED, GATE, BUTTWELD

## SIZES AVAILABLE:

3" - 48" (80mm - 1200mm)

---

## SEAT & SEAL RING

Fully replaceable seat and seal ring system extends the overall life of every Tri Lok valve minimizing downtime, without the need for costly offsite repairs or total replacement.

## STEM

Tri Lok's unique splined disc-to-stem connection minimizes hysteresis, eliminates external connections (and associated hardware) and allows for easy assembly/disassembly.

Tri Lok features a one piece stem with a blow out prevention ring located above the packing box, outside the pressure boundary, in accordance with international standards.

In accordance with API 609, every stem is indexed providing positive local indication of disc/seal ring location once installed in the piping system.





## ASME CLASS:

150, 300, 600, 900

## TEMPERATURE RANGE:

-320°F to 842°F (-196°C to 450°C)

## BEARINGS

Bearing seals minimize ingress of media into the journal and are furnished as standard.

Stem bearings are elongated to provide maximum support of the stem.

## PACKING

Fully adjustable stem seal system (packing gland) eliminates fugitive emissions and is also field replaceable.

**Bray** **TriLok**<sup>®</sup>

A Division of Bray International, Inc.

The Ultimate Critical Service **TRIPLE OFFSET VALVE**



Design & Model

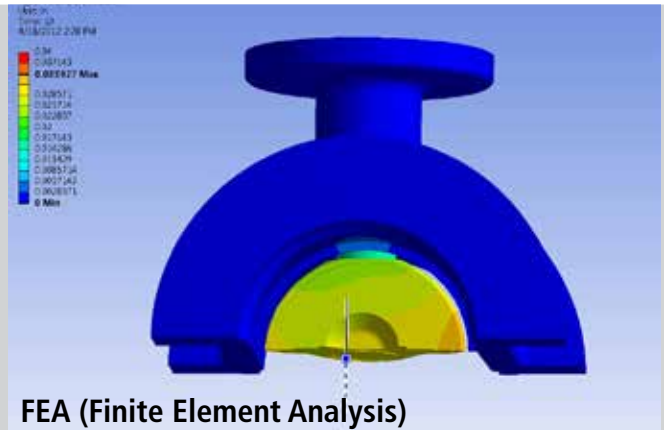

FEA (Finite Element Analysis)

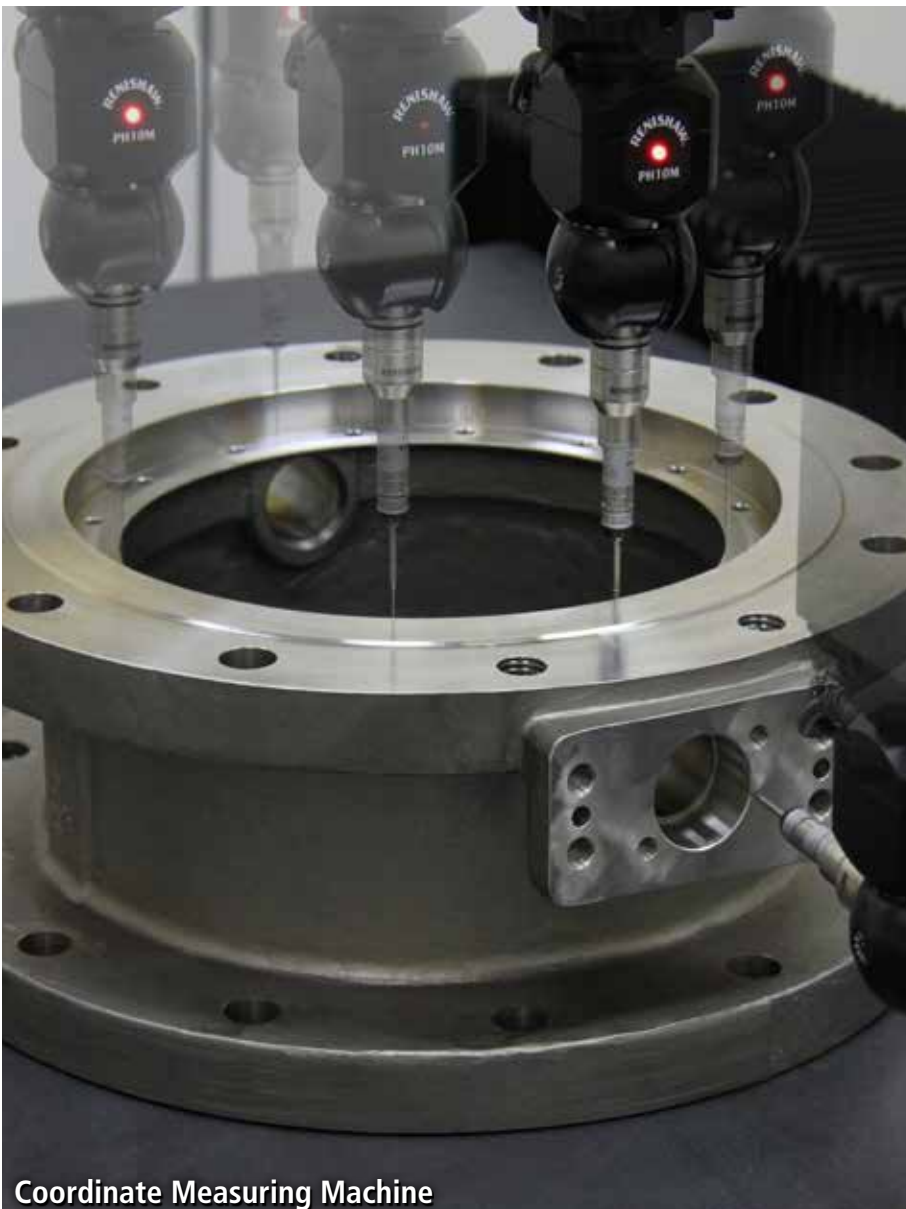

Coordinate Measuring Machine

12" ASME 150 Double Flanged Body - Carbon Steel

## DESIGN

Bray's research and development team utilizes the latest technology to design every component for optimal performance through its full pressure/temperature range.

## ANALYZE

Electronic prototypes are subjected to dimension verification as well as pressure and temperature simulations (FEA) in an effort to confirm the design and expose potential weakness in a "virtual" environment. This process ensures the actual product is "fit for purpose" prior to manufacture.

## VALIDATE

Individual materials and assemblies are subjected to a rigorous testing protocol prior to production release and during manufacturing. After assembly each valve is actuated and tested prior to shipment.

## CERTIFY

Tri Lok products are also performance tested for certification of capabilities such as fire safe, fugitive emissions, flow capacity, shock/vibration resistance and safety integrity (SIL) among others.

TESTED

ZERO LEAKAGE



Firesafe



Cryogenic



Shock & Vibe



Steam Cycle



# TRIPLE OFFSET TECHNOLOGY APPLICATIONS

Compared to gate, globe or ball valves of the same size and pressure class, Tri Lok provides space and weight savings while minimizing installation and maintenance costs.

Tri Lok is a premier isolation valve, well suited for operation in vacuum to high pressure as well as cryogenic to high temperature applications. The standard, non-rubbing, metal-to-metal sealing system is inherently firesafe. Applications requiring absolute zero leakage are ideally suited for triple offset technology.



20" ASME 150  
Gate Body - B16.10 face to face  
Carbon Steel



24" Cryogenic ASME 150  
ISO Flanged- Stainless Steel



Side

Front

# MATERIALS OF CONSTRUCTION

Valve bodies and discs are available in WCB Carbon Steel and CF8M Stainless Steel as standard. Low temperature Carbon Steel, Duplex Stainless Steel, Monel, Hastelloy® and NiAB are also available. The discs primary function is to "carry" the seal ring. As such, the disc material is commonly the same material as the body to allow full pressure/temperature rating and maintain uniform thermal expansion at elevated temperature. Standard stem materials are 17-4PH, 410 Stainless Steel and XM-19 (Nitronic®). Seat, seal ring and remaining trim are selected to meet the required mechanical properties while providing sufficient corrosion resistance. While the previously mentioned materials are defined as standard, custom engineered configurations are also available.



8" ASME 600  
Buttweld Body - Carbon Steel



4", 8", 12" ASME 150  
Nickel Aluminum Bronze





# Service - Testing - Automation - Repair

FOR THE ENTIRE LINE OF BRAY'S FLOW CONTROL SOLUTIONS







Hydrostatic & Seat Testing

48" ASME 150 Double Flanged Body - Carbon Steel

Full service facilities are located strategically around the globe to provide the ultimate customer experience. Each location is trained to automate, test and repair TriLok valves. These locations have the tools, knowledge, and inventory to care for the demands of critical service. Thus, TriLok products may be maintained in the region where they are installed to minimize downtime and associated cost.

All factors considered



A Division of Bray International, Inc.

is the ultimate critical service  
triple offset valve



**GLOBAL MANUFACTURING,**

TO SERVE YOU LOCALLY, EACH REGION MAINTAINS A  
FACTORY CERTIFIED SALES AND SERVICE NETWORK  
FOR ALL BRAY INTERNATIONAL PRODUCTS.

**SERVICE AROUND THE CORNER**

**Bray TriLok**

A Division of Bray International, Inc.

All statements, technical information, and recommendations in this bulletin are for general use only. Consult Tri Lok representatives or factory for the specific requirements and material selection for your intended application. The right to change or modify product design or product without prior notice is reserved. Patents issued and applied for worldwide.

Tri Lok® is a registered trademark of  
BRAY INTERNATIONAL, Inc.  
© 2012 Tri Lok. All rights reserved.

B-1039\_EL\_TriLok\_2012-05

[www.trilokvalve.com](http://www.trilokvalve.com)